

# EmoTouch 3

## Control Unit for Sauna Cabins



Operating Instructions

**Made in Germany**



Druck-Nr.: 2902 5151  
Stand: 48/20

# Documentation

## Manufacturer

EOS Saunatechnik GmbH	
Schneiderstriesch 1	
35759 Driedorf, Germany	
Tel.	+49 2775 82-514
Fax	+49 2775 82-431
Email	servicecenter@eos-sauna.com
Web	www.eos-sauna.com

## Original installation instructions EN







Copyright for these installation instructions remains with EOS Saunatechnik GmbH.

Copyright as per DIN ISO 16016:

The copying and distribution of this document, as well as the use and communication of its contents without express authorisation, are not permitted. Compensation will be claimed in the event of infringements.

All rights reserved with regard to patent claims or submission of design or utility patent.

## Characters, symbols and illustrations

-  Additional information about an operating step
-  Cross-reference to a page
-  Read instructions
-  Result of a step
-  Table title
-  Title of figure

## Revision history

Date	Version	Description
1 Aug. 2020	01.00	First version
15 Jan. 2021	01.10	Chapters Safety, Standards and regulations, and Potential-free contact updated

# Contents

<b>Documentation</b> .....	EN-2
<b>1 General safety instructions</b> .....	EN-5
1.1 Safety levels.....	EN-5
1.2 Operation and settings.....	EN-6
1.3 Operator instruction.....	EN-7
1.4 Standards and regulations.....	EN-9
<b>2 Identification</b> .....	EN-10
2.1 EmoTouch 3 control panel.....	EN-10
2.2 Intended use.....	EN-11
<b>3 Description of the units</b> .....	EN-12
3.1 Scope of delivery.....	EN-12
3.2 Technical data.....	EN-14
<b>4 Commissioning</b> .....	EN-15
4.1 Configuration upon commissioning or after a reset.....	EN-16
4.2 Defining the light source manually.....	EN-23
<b>5 Operation</b> .....	EN-26
5.1 User interface.....	EN-26
5.2 Working with the graphic user interface.....	EN-27
5.3 Switching the system on/off.....	EN-28
5.4 Basic settings.....	EN-31
5.4.1 Setting the temperature.....	EN-32
5.4.2 Selecting the operating mode.....	EN-33
5.4.3 Setting the humidity for Bi-O mode.....	EN-34
5.4.4 Dimming or switching the light on/off.....	EN-36
5.4.5 Retrieving temperature/humidity values.....	EN-37
5.4.6 Switching ECO mode on/off.....	EN-38
5.4.7 Switching on HOT mode.....	EN-41
5.4.8 Switching potential-free contact on/off.....	EN-43
5.5 Advanced settings.....	EN-44
5.5.1 Advanced settings – single installation.....	EN-45
5.5.2 Advanced settings – multi-cabin installation.....	EN-46
5.5.3 Language selection.....	EN-50
5.5.4 Screen saver.....	EN-52
5.5.5 Standby mode.....	EN-53
5.5.6 Operational lock/child lock.....	EN-54
5.5.7 Display brightness.....	EN-56
5.5.8 Holiday cottage mode.....	EN-57
5.5.9 Operating data.....	EN-59

5.5.10	Heating period – auto stop .....	EN-61
5.5.11	Automatic start time .....	EN-63
5.5.12	One-time heating period .....	EN-65
5.5.13	Recurring heating periods .....	EN-69
5.5.14	Coloured light coupling.....	EN-76
5.6	Error messages .....	EN-79
<b>6</b>	<b>Service settings</b> .....	<b>EN-80</b>
6.1	Service level .....	EN-80
6.1.1	Opening service settings.....	EN-82
6.1.2	Service/maintenance.....	EN-83
6.1.3	Switching hysteresis .....	EN-84
6.1.4	Reset function .....	EN-85
6.1.5	Temperature control.....	EN-86
6.1.6	Setting the potential-free contact .....	EN-87
6.1.7	Fan levels .....	EN-89
6.1.8	Fan post-cycle period .....	EN-90
6.1.9	Refill period .....	EN-92
6.1.10	Post-heating time .....	EN-93
6.1.11	Post-heating temperature .....	EN-94
6.1.12	HOT function .....	EN-95
6.1.13	Setting the ECO runtime .....	EN-97
6.1.14	HOME function.....	EN-98
6.2	Data transfer and updates .....	EN-100
6.2.1	Configuration backup .....	EN-101
6.2.2	Updating firmware .....	EN-104
6.2.3	Exporting the operating data .....	EN-107
<b>7</b>	<b>General terms and conditions of service</b> .....	<b>EN-108</b>
<b>8</b>	<b>Disposal</b> .....	<b>EN-111</b>

# 1

## General safety instructions

### 1.1 Safety levels

Safety instructions and important operating instructions are classified according to ANSI Z535.6. Please familiarise yourself with the following terms and symbols:

#### **WARNING**

##### **Warning**

Indicates a hazardous situation which, if not avoided, could result in death or serious injury.

#### **CAUTION**

##### **Caution**

Indicates a hazardous situation which, if not avoided, could result in minor or moderate injury.

#### **NOTICE**

##### **Notice**

Indicates a hazardous situation which, if not avoided, will result in damage to the unit.

## General safety instructions

### 1.2 Operation and settings

These operating instructions are intended for the personnel responsible for the operation of a sauna cabin. Observe the following general safety instructions during set-up and operation.

#### **Risk to life and limb and risk of fire**

Risk to life and limb from electric shock and fire in the event of improper or faulty electrical connection. This risk also applies following completion of the installation work.

- ▶ The electrical installation of the relay box and other electrical systems or equipment with a fixed mains connection must only be performed by a trained electrician from an authorised electrical company.
- ▶ Observe the stipulations in VDE 0100 part 701.
- ▶ The system must be disconnected and removed entirely from the mains supply before commencing installation and repair work.
- ▶ The housing cover must only be removed by a specialist.

#### **Fire hazard from overheating**

Insufficient ventilation can lead to device overheating and fire. Flammable parts must not exceed a temperature of 140°C when the unit is operated as intended or in the event of a malfunction.

- ▶ Do not install control panels, relay boxes and modules in enclosed cabinets or wood panelling.
- ▶ Observe the sauna heater manufacturer's safety and installation instructions.
- ▶ Observe the cabin manufacturer's safety and installation instructions.
- ▶ Touchable glass surfaces on the outside of the cabins could reach a maximum of 76°C. Attach safety devices if needed.

#### **Damage to the unit**

Corrosive or heavy saline atmospheres damage the contacts in the control panel, in the relay box and in the sensors.

- ▶ The control panel and sensors should not be installed in a corrosive or heavy saline atmosphere.

## **Damage due to incorrect mounting location**

The control unit is not suitable for outdoor use.

- ▶ It must be operated only inside buildings and may not be exposed to environmental conditions such as extreme humidity and moisture or the possible formation of condensation or corrosive substances in the ambient air, as well as other weather conditions.
- ▶ Similarly, excessive cold and extreme exposure to sunlight must be prevented.
- ▶ Protect the unit accordingly if there is an increased risk of mechanical damage.

## **1.3 Operator instruction**

The operator of the infrared or sauna cabin must be instructed in the general safety instructions during commissioning. The operator must be given a copy of the operating instructions.

The operator must make the end user aware of safety instructions that are relevant to the end user.

## **Risk of electric shock**

A risk to life and limb from electric shock and fire arises in the event of improper repair work. This risk also applies after work is completed.

- ▶ The unit covers must only be removed by a specialist.
- ▶ Repairs and installations must only be performed by a trained specialist.
- ▶ The system must be disconnected and removed entirely from the mains supply before commencing repair work.
- ▶ Use only original spare parts from the manufacturer.

## **Fire hazard**



Objects placed on the sauna heaters can easily be ignited and cause fires.

- ▶ Do not place objects on the sauna heater.
- ▶ If you switch on the sauna heater using pre-set timers or a remote control, attach a protective cover to the heater or install a suitable safety device.
- ▶ Inspect the cabin prior to commissioning.
- ▶ When using control units with a remote control option (see EN 60335-1), protection from switching on a covered sauna heater is required.

## General safety instructions

- Risk of burns and chemical burns** Touching hot parts may lead to skin burns and chemical burns of the skin.
- ▶ The operator must be familiar with the unit's hot parts and be able to identify them.
  - ▶ The operator must be familiar with the settings for the heating period and understand how it is controlled.
- Health risks** Spending time in an infrared or sauna cabin can lead to serious health risks or even death for persons with health impairments.
- ▶ Persons with health impairments who spend time in a sauna must consult a doctor before entering an infrared or sauna cabin.
- Equipment damage due to overuse** The uninterrupted operation time of the sauna cabin(s) can lead to property damage.
- ▶ If the sauna cabin is used commercially, the heating time must be set so that it switches off automatically after a specific period of time.
  - ▶ If the heating does not switch off automatically after a defined heating period, cabin use must be supervised at all times.
  - ▶ Inspect the cabin before each use.
- Operation by children or persons with reduced mental capacity** Children and persons with reduced mental capacity can be a risk.
- ▶ Children must be supervised to ensure they do not play with the unit.
  - ▶ Children under 8 years of age should not operate the sauna cabin.
  - ▶ The settings for the heating time must only be used by children under 8 years of age if they are supervised by an adult.
  - ▶ The sauna cabin must only be used by persons with reduced mental capacity, or limited physical or sensory abilities under supervision or if they have already been instructed in its use and understand the risks.
  - ▶ Children and persons who have not received proper instruction must not clean or service the system.



## **1.4 Standards and regulations**

For an overview of the standards that were observed during design and construction of the sauna heaters, please refer to the individual product's technical data sheet that can be downloaded from [www.eos-sauna.com](http://www.eos-sauna.com). Local regulations also apply to the installation and operation of heating, sauna, and steam room systems.

## 2

## Identification

The EmoTouch 3 control unit consists of a relay box, a control panel, a temperature sensor and the connecting cables, and is used to operate a sauna cabin.

### 2.1 EmoTouch 3 control panel

The nameplate is attached to the back of the control panel.

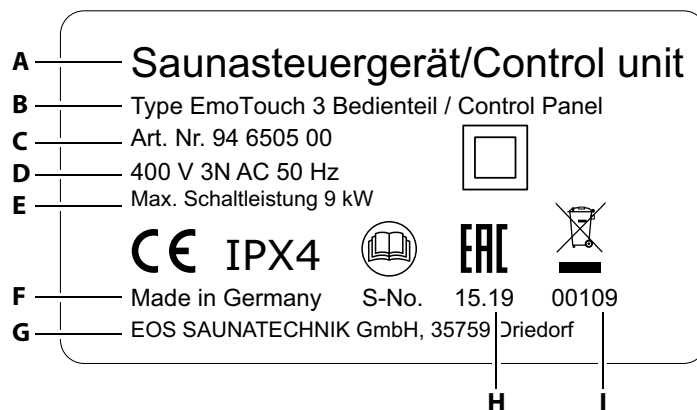

- |   |                             |
|---|-----------------------------|
| <b>A</b> Name   | <b>F</b> Country of origin  |
| <b>B</b> Model  | <b>G</b> Manufacturer       |
| <b>C</b> Item number  | <b>H</b> Manufacturing date |
| <b>D</b> Operating voltage  | <b>I</b> Serial number      |
| <b>E</b> Maximum switching output (kW)  |                             |
|  Nameplate (example) |                             |

#### Requirements for operation and storage

The control panel must be installed outside of sauna cabins only. The mounting location must meet the following climate condition requirements:

- Ambient temperature during operation -10°C to 35°C
- Storage temperature: -20°C to 60°C

## 2.2 Intended use

In conjunction with a suitable sauna heater, the EmoTouch 3 control unit is intended to be used only to heat sauna cabins. It is suitable for cabins used in private and commercial settings.

The relay box and control panel are intended only for mounting on the wall.

The control unit is not suitable for outdoor use.



It must be operated only inside buildings and may not be exposed to environmental conditions such as extreme humidity and moisture or the possible formation of condensation or corrosive substances in the ambient air, as well as other weather conditions. Similarly, excessive cold and extreme exposure to sunlight must be prevented. Protect the unit accordingly if there is an increased risk of mechanical damage.

### EmoTouch 3 relay box

The relay box is used to operate sauna heaters in Finnish mode and in humidity mode.

### EmoTouch 3 control panel



The EmoTouch 3 control panel is suitable for the operation of sauna cabins in private and commercial settings. It must be mounted on a wall.

### Foreseeable misuse

The following are considered instances of foreseeable misuse:

- The control and sensor cable plugs are plugged in incorrectly.
- The unit is operated without knowledge of or compliance with the safety instructions.
- Operating, service and maintenance requirements are not observed.
- The unit is operated after technical or other modifications are made to the relay box.
- The unit is operated by children or persons with reduced mental capacity or by persons who have not been thoroughly instructed in its use.

The manufacturer is not liable for unauthorised modifications made to the equipment and damages resulting from these modifications. The person modifying the equipment alone shall bear the associated risk.

 General safety instructions,  EN-5

## Description of the units

## 3

## Description of the units

## 3.1 Scope of delivery

The following components are included in the scope of delivery:

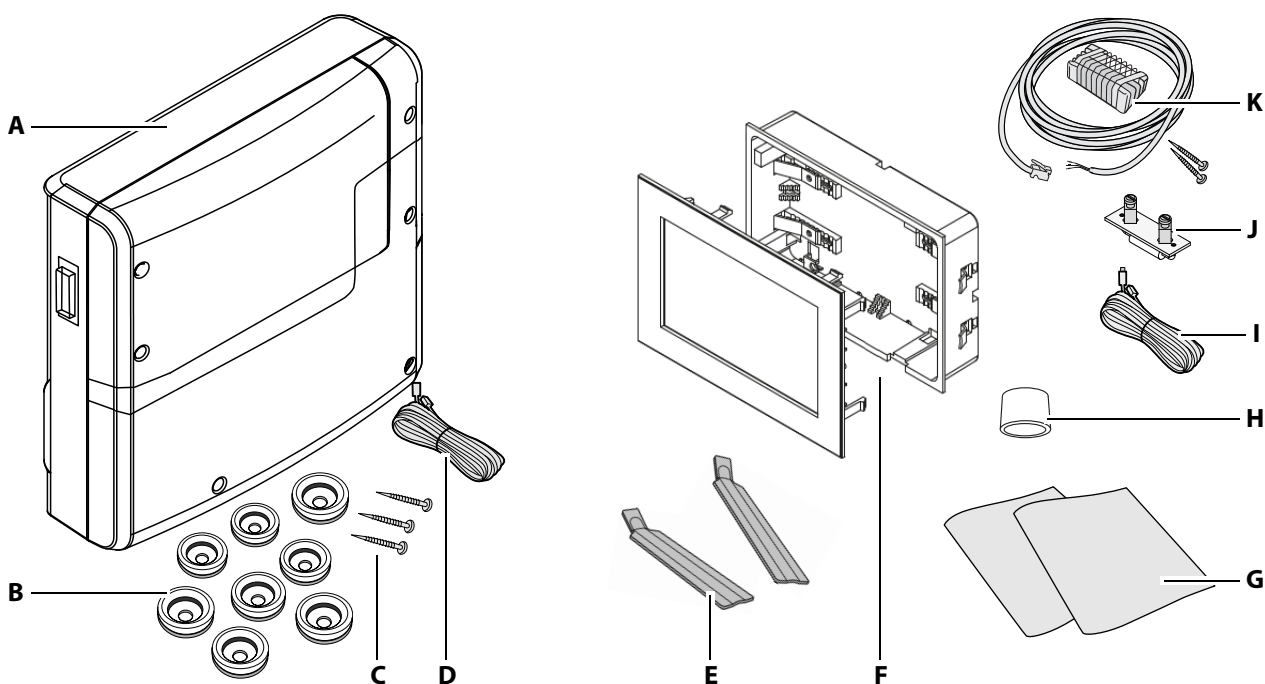

**A** Relay box with 2-piece front cover

**B** 8 bushings

**C** 3 wood screws 4 x 25 mm

**D** 5 m connecting cable with RJ14/RJ10 modular plug for control panel

**E** Removal tools for control panel

**F** EmoTouch 3 control panel with housing for mounting in the wall

**G** Installation and operating instructions

**H** Ferrite ring for data lines

**I** Line for safety temperature limiter

**J** Spare fuse for safety temperature limiter

**K** Temperature sensor including 5 m connecting cable with RJ10 plug, housing, circuit board, 2 screws 4x40 mm

 EmoTouch 3 scope of delivery

Check the scope of delivery for completeness prior to installation.

## Accessories (optional)

Accessories	Item no.
20 m connecting cable for temperature sensor	94.6281
50 m connecting cable for temperature sensor	94.6282
10 m connecting cable for control panel (RJ10/RJ14)	94.6802
25 m connecting cable for control panel (RJ10/RJ14)	94.6285
50 m connecting cable for control panel (RJ10/RJ14)	94.6968
100 m connecting cable for control panel (RJ10/RJ14)	94.6969
10 m connecting cable for sauna bus (RJ12/RJ12)	94.5861
25 m connecting cable for sauna bus (RJ12/RJ12)	94.4647
50 m connecting cable for sauna bus (RJ12/RJ12)	94.4648
Mains adapter 230 V for control panel with cable length > 25 m	94.6671
Bench sensor	94.5725
Humidity sensor	94.5726
SBM-HOT (button)	94.6800
SBM-ECO (button)	94.6980
IR module as installation add-on	94.6966
IR plug-in module with adapter cable	94.2046
IR plug-in module without adapter cable	94.4960
2.5 m connecting cable for IR plug-in module	94.4396
Set SBM ECO push button	94.6980
SBM-WCI-01 web app module	94.5987
SBM remote start	94.5782
SBM-FL75/150 coloured light module	94.5996, 94.6007
SBM-S BT sound module	94.5920, 94.5921
Infrared receiver for coloured light module and sound module	94.6810
SBM-GLT-MOD HOME Modbus module	94.7077
SBM-GLT-KNX HOME KNX module	94.7078
Modular distributor RJ12 for connecting cable for control panel and sauna bus	2001.5298

## Description of the units

### 3.2 Technical data

Power supply	400 V 3 N AC 50 Hz
Switching output	Max. 9 kW resistive load, upgrade with LSG units possible
Fuse	3 x 16 A
Ambient temperature	-10°C to +35°C
S1 output	Max. 50 W/50 VA (no capacitive loads)
Supply for terminal area/sauna heater connection	0.5–2.5 mm <sup>2</sup> rigid or flexible with wire-end ferrule, two conductors with identical cross-section per terminal can be connected.
Terminal area WM, 3, 4, light, fan	0.34–2.5 mm <sup>2</sup> rigid or flexible with wire-end ferrule. Observe minimum cross-sections for fuse protection for the supply line.
Potential-free contact	Load rating of contact for resistive loads: - Maximum power supply: 10 A - Maximum voltage: 30 VDC/250 VAC
Storage temperature	-20°C to +60°C
Relay box housing	Plastic
Dimensions (H x W x D)	270 x 300 x 100 mm Control panel: 142 x 210 x 42 mm, mounting depth approx. 37 mm
Weight	Relay box: approx. 1.5 kg
Relay box outputs/inputs	3 x RJ10 jack for sensor connection 2 x RJ14 jack for control panel and add-on modules
Control panel outputs/inputs	4 x RJ10 jack for relay box and multi-cabin connection 1 x connection for memory card (input/host, jack type A) Connection for power adapter 24 V DC
Display	Colour capacitive 7" touchscreen display in 16:9 format Error display: Text on the display
Heating time limitation	Up to 6 hrs/12 hrs/18 hrs/infinite
Temperature control	30°C–115°C (dry sauna mode) 30°C–70°C (humidity mode)
Humidity regulation	Time-proportionally or optionally according to % rel. air humidity with connected humidity sensor
Sensor system	Digital sensor with safety temperature limiter 139°C
Control characteristics	Digital two-point control
Connection for fan*	Min. 5 W, max.150 W (only fan without starting capacitor) Use only fans that are suitable for phase control, otherwise the fan or the control unit can be damaged.
Connection for lighting*	Min. 5 W (20 mA), resistive load, max. 100 W Dimmable energy-saving bulbs, max. 35 W Light source with conventional transformers, max. 60 VA. Use only dimmable light sources.

\* Fan and light connections are protected by a joint 2AF fuse.

# 4

## Commissioning

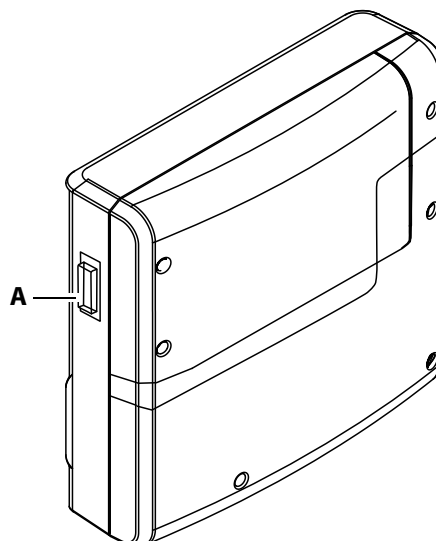

### A Unit switch on relay box

In order to commission the sauna cabin, the cabin must be switched on at the control panel. If the display is blank, the relay box might be switched off.

A unit switch is located on the left side of the relay box.



#### Position I:

Relay box is switched on (factory setting).

The relay box is ready for operation in standby mode.



#### Position 0:

Relay box is completely switched off.

Parts of the circuit board are still under current.



#### Position II:

Cabin lighting is switched on, relay box is switched off.

Position for maintenance and cleaning.

## 4.1 Configuration upon commissioning or after a reset

The control panel automatically switches to standby mode once connection to the relay box has been established and it is connected to the mains supply.

The settings must be redefined upon commissioning and after a complete system reset. The program guides you through the required steps.

### ► Defining the user interface language

- 1 Tap the desired language.

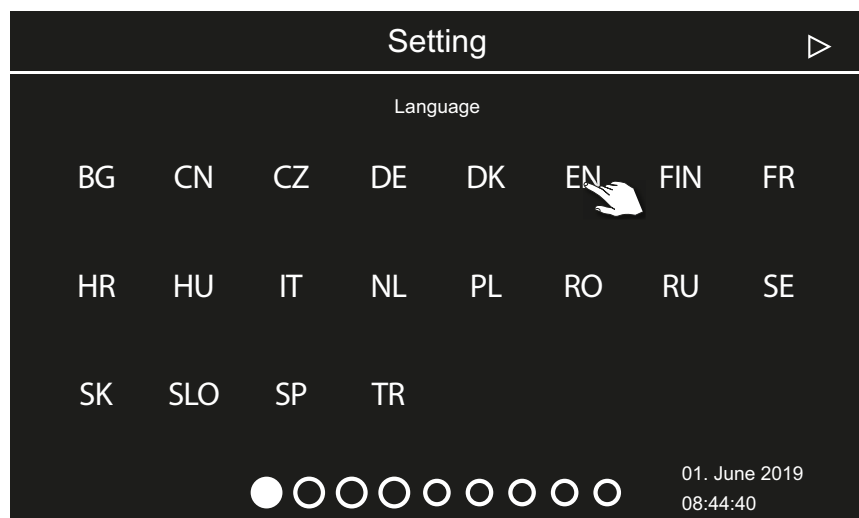

- 2 Tap the language again to confirm the selection.
  - Once confirmed, the display moves to the next setting.



## ► Setting the time

- 1 Set the hours with **+** and **-**, and then confirm.

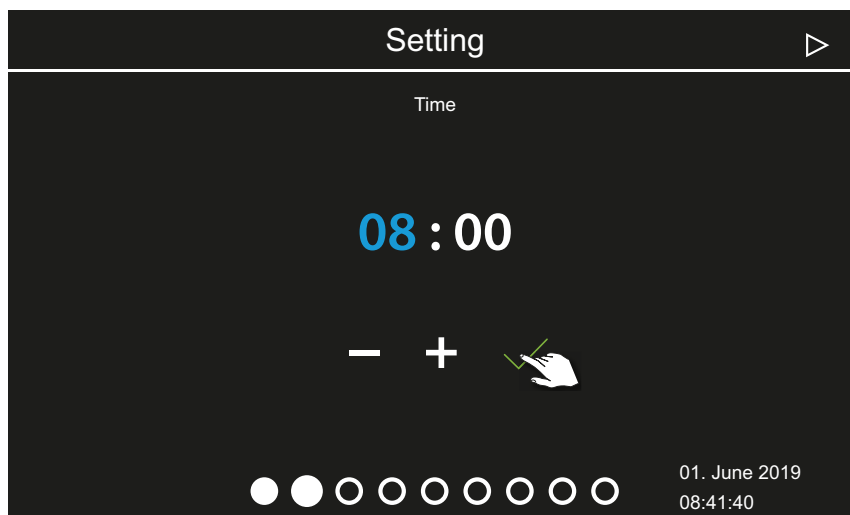

- ① The active place value appears in blue.
- ① Pressing and holding the button changes the value in increment mode.

- 2 Set the minutes and confirm.

## ► Setting the date

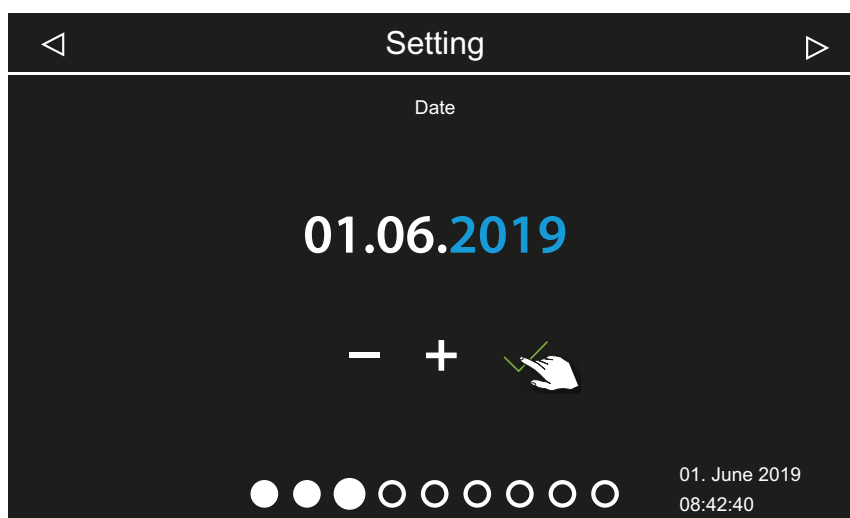

- 1 Set the day, month, and year by pressing **+** and **-**, and then confirm.



- ① The active place value appears in blue.

# Commissioning

## ► Specifying the place of operation

- 1 Press  or  to confirm the prompt that asks if the system is being operated in a country of the EU/CENELEC.

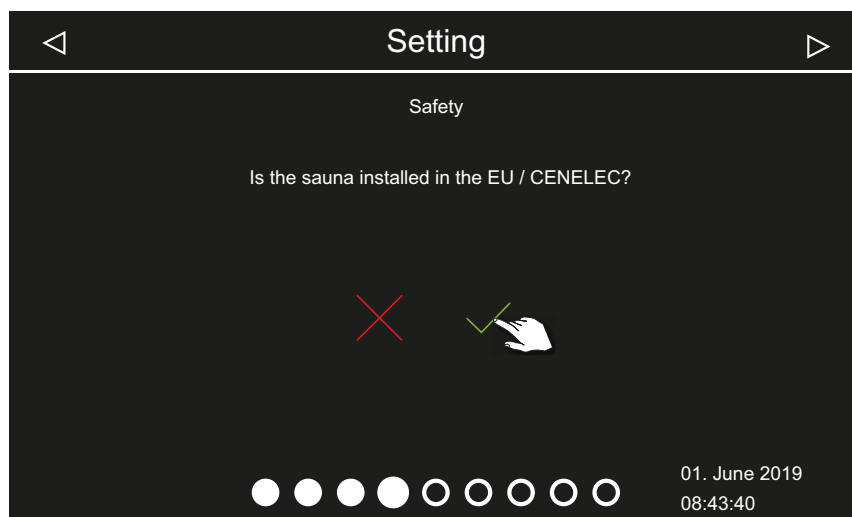



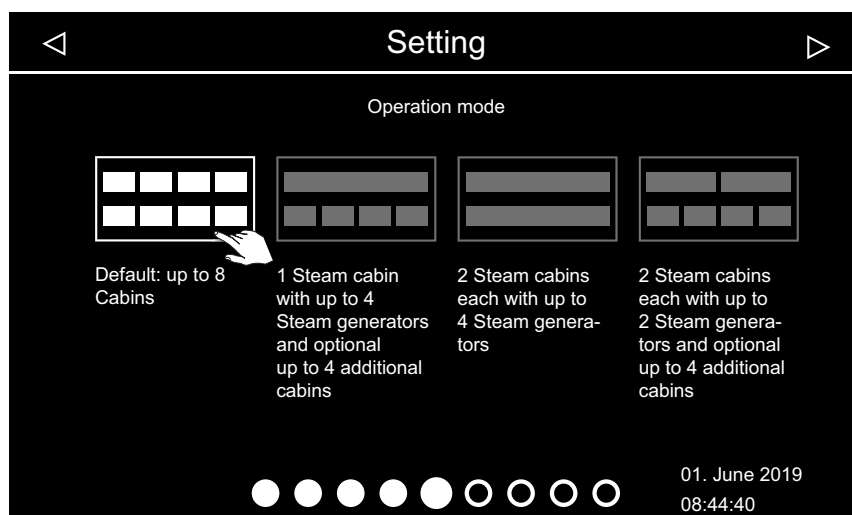

- ① European Union/CENELEC must be selected if the system is installed in countries under the jurisdiction of the CENELEC.
- ① Once EU/CENELEC is selected, specific provisions of the EU/CENELEC apply, e.g. the time limit for operation.

## ► Selecting the operating mode



- 1 Tap the desired operating mode.



- ①  Choose this setting if one steam generator or one sauna heater per cabin is controlled. For more information about installing multiple cabins, see the installation instructions.
- ①  Choose this setting if one cabin is served by 1–4 steam generators. Additionally, 4 more cabins can be controlled with steam generators or sauna cabins.
- ①  Choose this setting if 2 cabins, each with up to 4 steam generators, are operated.
- ①  Choose this setting if 2 steam room cabins, each with up to 2 steam generators, are operated. Additionally, 4 sauna cabins or IR cabins can be operated.

2 Confirm the selection.

## ► Defining the type of use

- 1 Press  or  to specify whether the system will be used for private or commercial purposes.

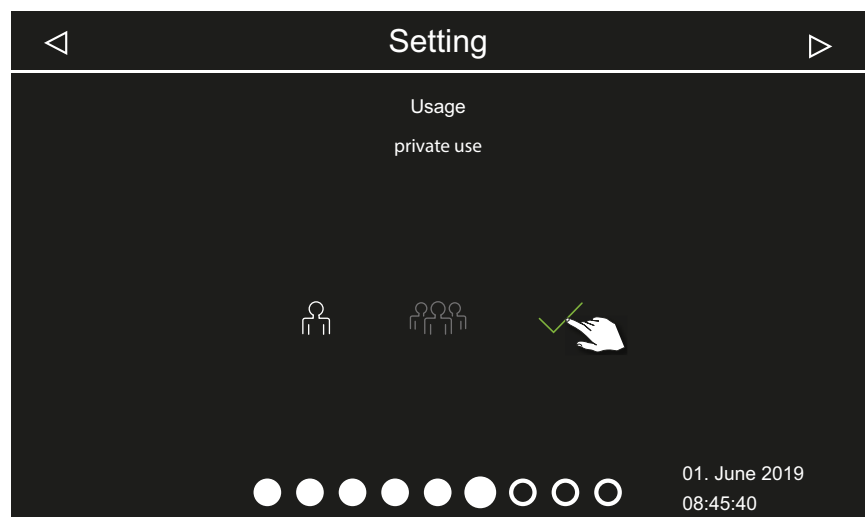

a)  Private use



b)  Commercial use

- ① Specific safety regulations apply to this setting. See 1.3 Operator instruction,  EN-7

2 Confirm the selection by pressing .

# Commissioning

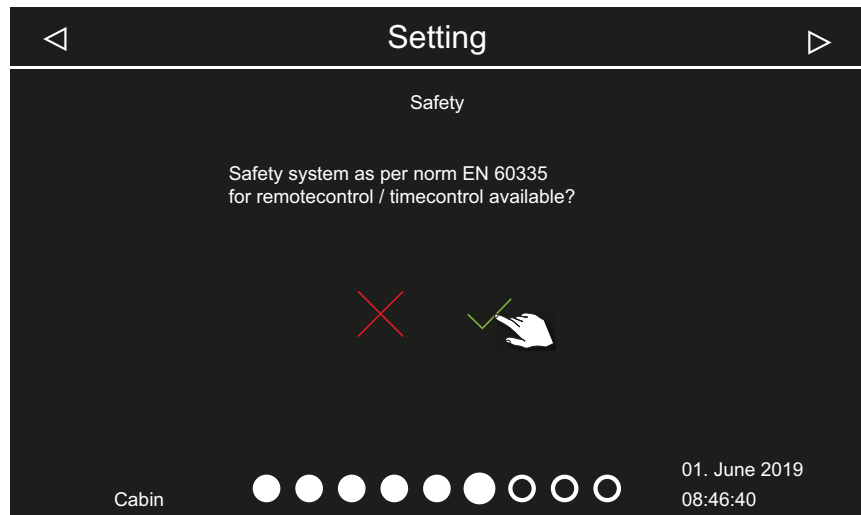

## ► Security settings

- 1 Press  or  to specify whether the system will be operated with a safety device.





- ① A safety device must be present to set up one-time and recurring heating periods, the remote start function, and the Web App WCI module.
- ① If you confirm the prompt by pressing , a message stating that the system does not comply with safety standards is displayed. Confirm the message.

## ► Selecting the heater type

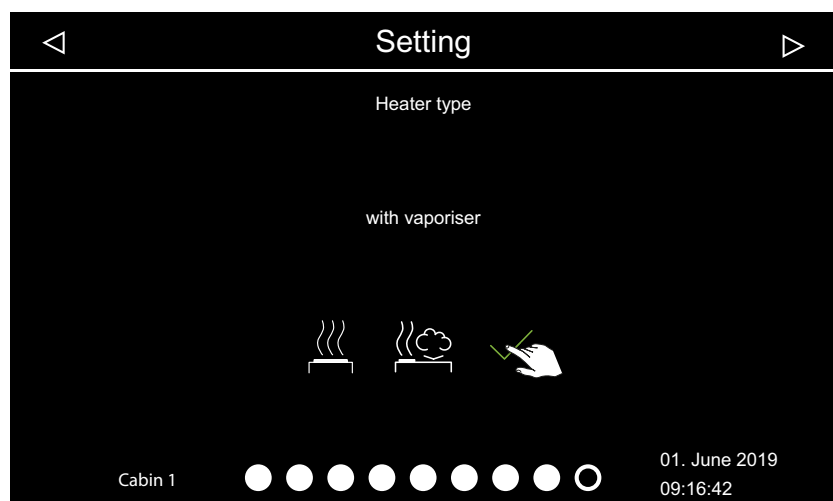
- 1 Press  or  to specify whether the sauna heater will be operated with or without a vaporiser.



a)  Heater type without vaporiser for Finnish sauna.

b)  Heater type with vaporiser.

① Select how the heater is displayed after selecting the skin for the cabin. ► Selecting skins,  EN-21

2 Confirm the selection by pressing .

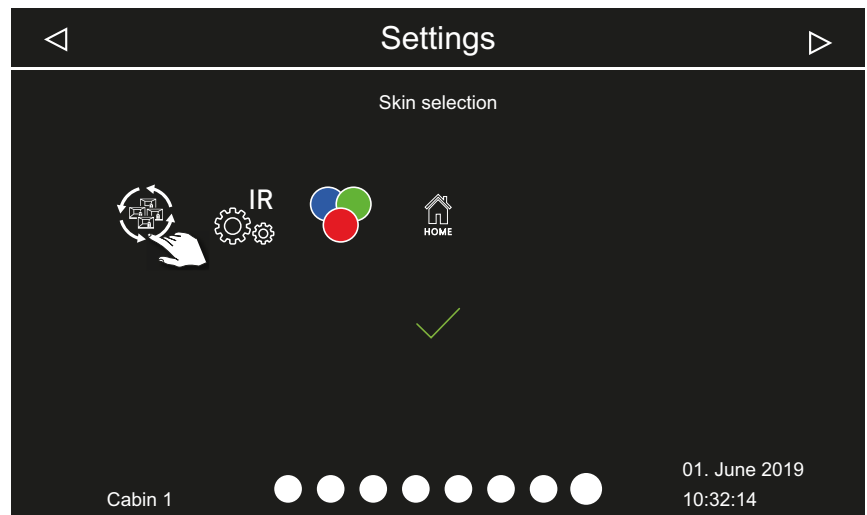

## ► Selecting skins

1 Open skin selection by pressing .



① The display shows only the installed and detected modules. Information about setting up the module can be found in each of the individual installation and operating instructions.

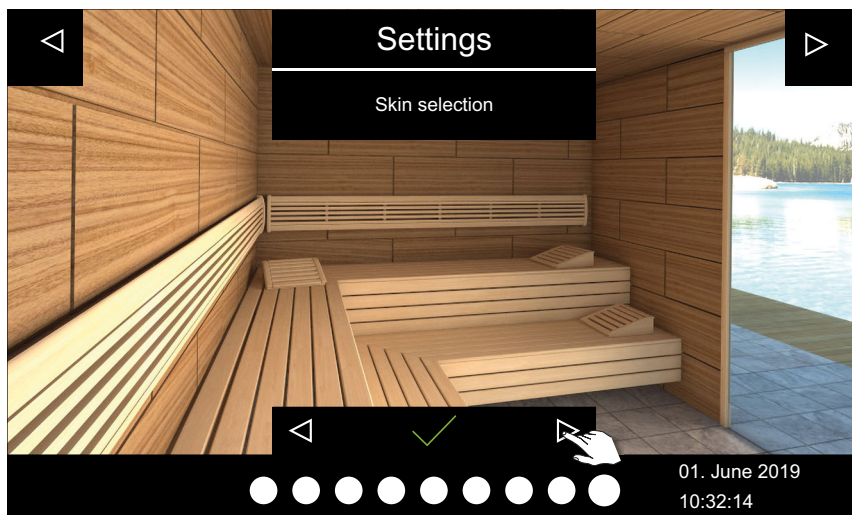

# Commissioning

- 2 Press the lower arrows  or  to scroll through the skins and confirm your selection.



- ① After selecting the skin and the heater image, selection of the connected module is displayed again.
- ① If the installation is a multi-cabin installation, the cabin image and the module for each cabin are set.

- 3 Confirm the selection by pressing .

- 4 Press the lower arrows  or  to scroll through the heater images and confirm the image for the sauna heater you want.

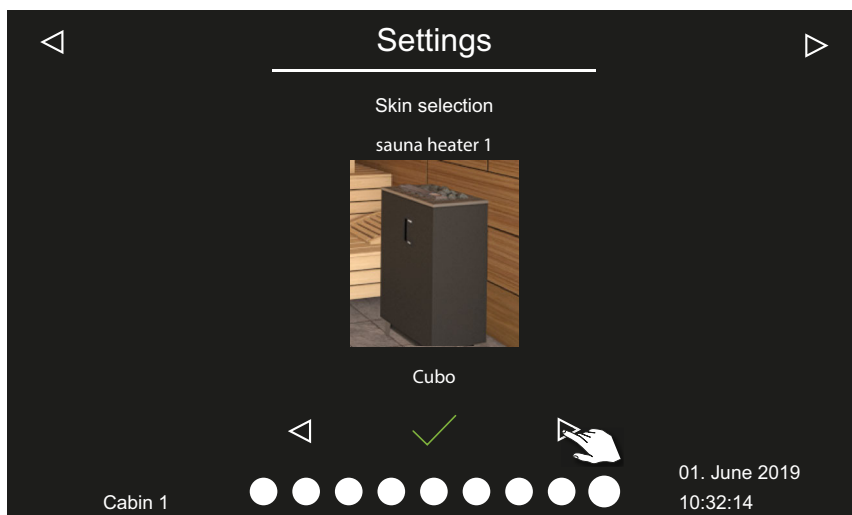



- ① After selecting the heater image, selection of the connected module is displayed again.

- 5 Confirm the selection by pressing .

This completes the initial setup. If the installation is a multi-cabin installation, you must set the cabin image and the heater image for each cabin.

Add-on modules or accessories are detected once the unit is switched on (again) and their corresponding icons appear on the cabin image and in the sub-menus.

 Additional settings:



5.4 Basic settings,  EN-31  
chapter Service settings,  EN-80

## 4.2 Defining the light source manually

The control unit is set to inductive loads by the factory so that resistive loads can also be controlled by the control panel. If required, the light output can also be manually set to capacitive loads.

If light bulbs are used, the load for lighting must remain as an inductive load.

The current setting is shown on the display.

Display symbol	Setting	Code
	Inductive/resistive load (lighting for phase control), if light bulbs are used. Factory setting	<b>8001</b>
	Capacitive load (lighting for phase control) Electrical ballasts for phase-cut dimmer	<b>8002</b>

### NOTICE

#### Material damage

Lighting and the control unit could become damaged if non-dimmable light sources are installed. In this case, the warranty becomes void.

- ▶ Work must only be performed by a trained technician from an authorised company specialised in the trade.
- ▶ Do not mount lights near rising steam.
- ▶ The lighting must conform to protection class IP65 and be resistant to ambient temperatures.
- ▶ Connect only dimmable light sources.

For this setting, the lighting must be disconnected.

# Commissioning

## ► Setting the load for lighting to resistive load

- 1 **WARNING!** Ensure that the relay box is disconnected from the power supply.  
Open the relay box's housing.  
① Refer to the installation instructions.
- 2 Disconnect the light source from the relay box.
- 3 Reconnect the power supply and switch on the relay box and control panel.
- 4 Press and hold  for 3 seconds.
- 5 Enter the code and confirm.

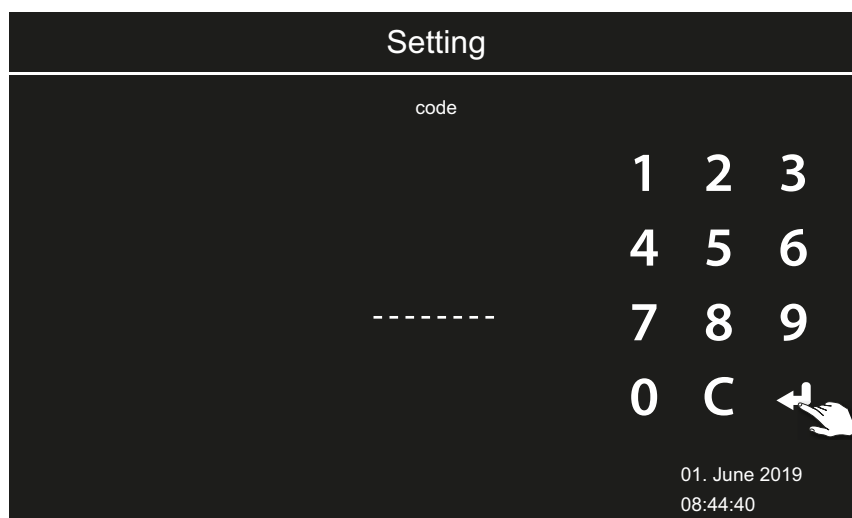

- ① Code **8001**: Inductive load/resistive load, e.g. if light bulbs are used.
- ① Code **8002**: Capacitive load.

- 6 Disconnect the relay box from the mains supply and reconnect the light source.
- 7 Close the housing again.
- 8 Reconnect the relay box to the power supply and switch it on.



**9** Press and hold the light icon on the display for 3 seconds.



① The icon for the current lighting load setting is displayed.

**10** Check the setting on the display.

## 5

## Operation

The figures show examples of the display and settings.

## 5.1 User interface



- |  |   |   |
|--|---|---|
| <b>A</b> Cabin image                                   | <b>G</b> Settings                                     | <b>K</b> Date, time, and possibly timer setting |
| <b>B</b> Temperature/humidity detector                 | <b>H</b> Warning (for a different cabin)              | <b>L</b> EOS logo (touch recognition)           |
| <b>C</b> Potential-free contact                        | <b>I</b> Actions and information, e.g. humidity mode  | <b>M</b> Cabin lighting                         |
| <b>D</b> Status bar                                    | <b>J</b> Current cabin (for multi-cabin installation) | <b>N</b> Sound (optional)                       |
| <b>E</b> On/off (cabin)                                |   | <b>O</b> Coloured light (optional)              |
| <b>F</b> Current status, e.g. amount of time remaining |   |   |

EmoTouch 3 graphic user interface layout – example

The touch screen function icons are displayed in various colours:

- Grey: Function button is inactive
- White: Function available, function button is selected
- Green: Function button *Confirm* is selected
- Red: Function button *Delete* is selected
- Blue: Settings, e.g. for timer

Texts are displayed in the following colours:

- White: Status texts, e.g. date, name of sub-menu
- Blue: active input digits, e.g. for date, time, timer display
- Red: Warning, time display for auto-stop

## Display

The display switches to standby mode if there is no activity for a defined period of time. You can cancel standby mode by tapping the display. Tap any area on the cabin image to close an open sub-menu.

- Sub-menus close automatically if the display is not touched for 10 seconds. After that, the start screen is displayed.
- If you have a multi-cabin installation, you can switch to the start screen by tapping the cabin number in the status bar.

All cabin settings are made at the control panel. At least one cabin must be set up for commissioning.

## 5.2 Working with the graphic user interface

The graphic user interface displays icons depending on the selection. Their use is described below:



Tap briefly on the cabin image: The function is switched on or off.

Tap briefly on the sub-menu: The icon is selected.

Tap again: The selection is confirmed.

Press and hold: A sub-menu opens.

Tap anywhere on the cabin image: The sub-menu for settings closes.



Heat on/off



Settings



Next



Back to previous selection or start



Confirm selection



Clear selection



Increase the value by 1.



Decrease the value by 1.

The home screen (standby) appears after the display has not been touched for 10 seconds.

- Settings that have not been saved are lost.
- Date and time are saved if the built-in battery is charged and in working order. All other settings are saved permanently.

Add-on modules or accessories are detected once the unit is switched on again and their corresponding images appear on the cabin image or in the sub-menus.

The display illustrations in these operating instructions always show examples with optional features.

Unit operation and unit settings are available on different levels:

User level	Private operation	
	Commercial operation	Basic settings (per cabin)
		Advanced settings (with PIN code)
Service level	Settings for service technician (with PIN code)	

### 5.3 Switching the system on/off

In a multi-cabin installation, you can start and end each cabin individually or all cabins at the same time.

- ▶ Switching on a single installation, [EN-29](#)
- ▶ Switching the system off, [EN-31](#)

Instead of starting the system manually, you can set an automatic start time or define a single start date.

- ▶ Setting the automatic start time, [EN-63](#)
- ▶ Setting a one-time heating period, [EN-65](#)

## ► Switching on a single installation

- 1 Press and hold  for 3 seconds.
  - ① If you have not selected a cabin in the multi-cabin installation, all cabins are started via the cabin overview. To prevent an overload of the mains supply, each cabin is started with a slight delay.



Example: Single installation

- ① The system is started using the parameters set for each cabin.



- ① The red (glowing) stones indicate that the heater is on.

### ► Switching on cabins in a multi-cabin installation

- 1 Select the cabin in the cabin overview.

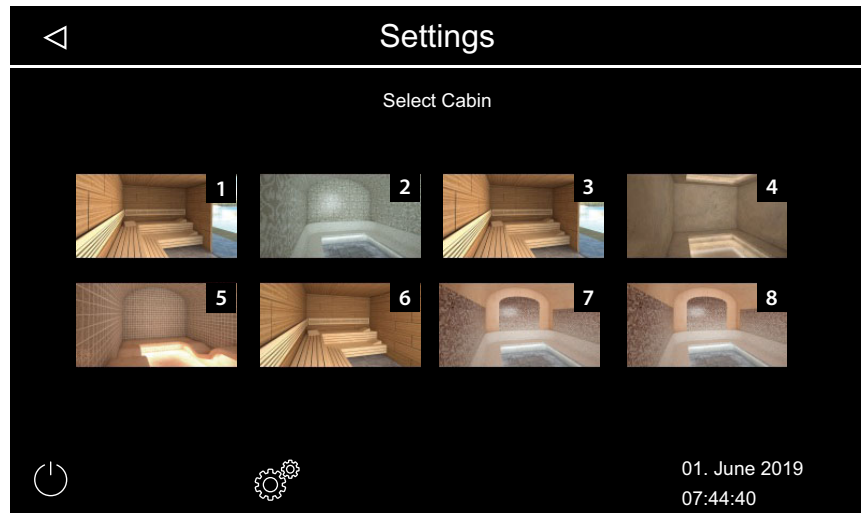

- ⓘ If you have not selected a cabin in the cabin overview, all cabins are started. To prevent an overload of the mains supply, each cabin is started with a slight delay.

- 2 Press and hold  for 3 seconds.

- ⓘ The system is started using the parameters set for each cabin.



- ⓘ The red (glowing) stones indicate that the heater is on in the selected cabin.

## ► Switching the system off

1 Tap .

- ① If you have not selected a cabin in the multi-cabin installation, all cabins are switched off via the cabin overview. To prevent an overload of the mains supply, each cabin is switched off with a slight delay.



 Example: Single installation

- ① After humidity mode is run, the fan that dries the cabin is switched on and runs for the set amount of time. Then the system switches to standby mode.
- ① Tap  again to end drying prematurely.

## 5.4 Basic settings

The most commonly used settings can be set directly in the interactive graphic user interface. These settings are available in both standby mode and operation mode.

The following descriptions apply to both private and commercial operation.

In multi-cabin operation, these settings must be defined separately for each cabin.

### 5.4.1 Setting the temperature

You can also set the temperature while the system is in operation. In humidity mode, temperature and humidity are controlled at the same time: ► Setting the humidity, EN-35.

#### ► Setting the cabin temperature

- 1 Press and hold the sauna heater image for 3 seconds.



Sample installation

- The sub-menu with the most recently saved temperature is shown.

- 2 Move the slider to the desired temperature.



- The cabin is immediately set to the new temperature.



## 5.4.2 Selecting the operating mode

You can choose between Bi-O mode or Finnish mode in a cabin with a supplementary vaporiser or a Bi-O sauna heater.

The following icons are displayed in the status bar:



Humidity mode



Finnish mode

▶ Switching on Bi-O mode, [EN-33](#)

▶ Switching on Finnish mode, [EN-33](#)

### ▶ Switching on Bi-O mode

1 Tap  in the status bar.

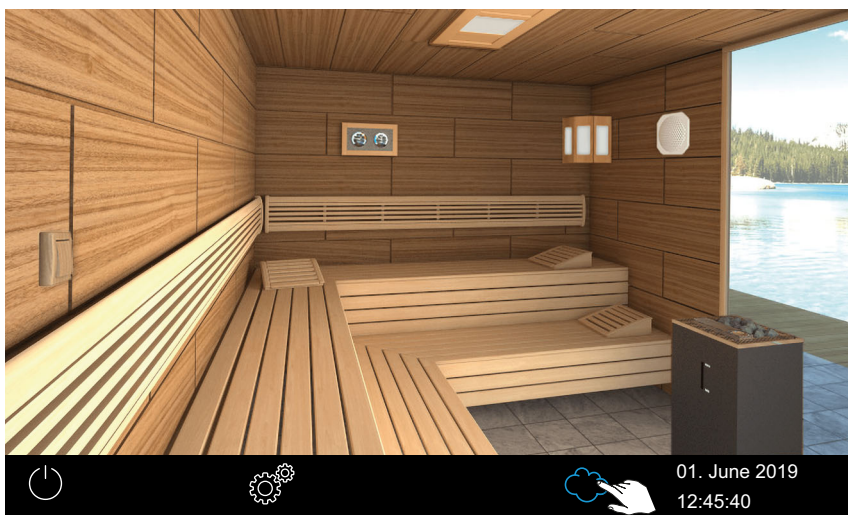

 Example: Single installation



The status bar displays an icon for humidity mode.

① If humidity mode is on, you can check and set the humidity and/or temperature as needed.

▶ Setting the humidity, [EN-35](#)

### ▶ Switching on Finnish mode

1 Tap  in the status bar.



The status bar displays the icon for Finnish mode.

### 5.4.3 Setting the humidity for Bi-O mode

An (optional) humidity sensor regulates the relative air humidity in %. At the same time, the control unit attempts to keep the set humidity as precisely as possible.

Air humidity can be regulated depending on the installation:

- If a humidity sensor is connected, the relative air humidity in % is set.
- If no humidity sensor is connected, an interval is set. This interval defines how long humidity mode is active in relation to the entire operating time.

The following icons are shown here:

#### Icons shown in the status bar



Humidity mode



Finnish mode

#### Icons shown in the sub-menu



With humidity sensor:  
Air humidity in percentage during humidity mode



Without humidity sensor:  
Humidity interval in humidity mode

#### With humidity sensor:

Humidity is regulated as shown in the following table:

- All values that lie below or on the characteristic curve can be set and used.  
When setting a parameter, e.g. temperature, the setting for the other parameter is automatically adjusted.
- Values that lie above the characteristic curve cannot be set.

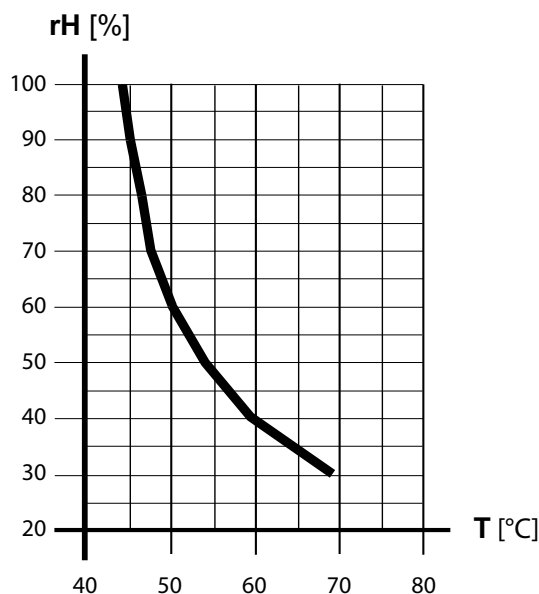

 Characteristic curve for temperature/humidity according to EN 60335-2-53

## Without humidity sensor:

The humidity is regulated in intervals.

Example

Humidity setting = 40

The vaporiser is running a total of 40% of the entire operating time.

This setting does not take into consideration the actual humidity in the sauna cabin and makes it possible to consistently produce a specific volume of steam, if required.

## ► Setting the humidity

- 1 Tap  in the status bar to switch to humidity mode.
- 2 Press and hold the sauna heater image for 3 seconds.
  - ① The sub-menu displays the values of the most recently saved temperature and humidity.
- 3 Slide the humidity slider to the desired value:

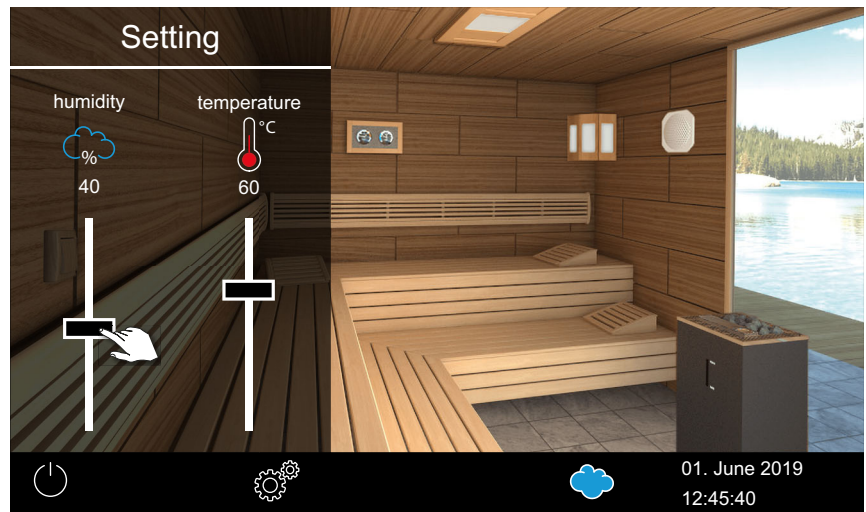

a)  : With humidity sensor.

b)  : Without humidity sensor.



 Example: With humidity sensor

① The temperature value is automatically decreased if it is not in line with the set humidity. See



 Characteristic curve for temperature/humidity according to EN 60335-2-53,  EN-34

① The temperature is only decreased, never increased.

#### 5.4.4 Dimming or switching the light on/off

You can switch the light on and off and dim it progressively by tapping the light image in the sub-menu.

The lighting is dimmed only if the cabin is switched on. If the cabin is switched off, the light always switches on as a “cleaning light” at full power. This allows you to have maximum illumination when cleaning the cabin.

- ▶ Switching the lighting on/off,  EN-36
- ▶ Dimming the light,  EN-37

##### ▶ Switching the lighting on/off

- 1 Tap the light image.



 Example: Single installation

- The light is switched on or off, depending on its current state.

## ► Dimming the light

- 1 Press and hold the light image for 3 seconds.



Example: Single installation

The menu with the current setting appears.

- 2 Move the slider to the desired light intensity.



The lighting is immediately adjusted accordingly.

## 5.4.5 Retrieving temperature/humidity values

You can retrieve the current (actual) and set (target) temperature at all times. This also applies to the humidity if humidity mode is on. The displayed values correspond to the values measured directly by the sensors. Due to the fact that, in a sauna, temperature zones vary greatly, the values can differ significantly from what is shown on the thermometer/hygrometer display on the wall.

We therefore recommend that you make adjustments to find the temperature/humidity values that work best for you.

### ► Retrieving temperature/humidity information

#### 1 Tap the thermometer/hygrometer image.

- ① The values for temperature and humidity are displayed in humidity mode; see 5.4.3 Setting the humidity for Bi-O mode, [EN-34](#)



- ① The actual and target values from the connected sensors are displayed for approx. 50 seconds.



- ① Setting temperatures, see the chapter on Service settings, [EN-80](#)

### 5.4.6 Switching ECO mode on/off

ECO mode can be activated during intermissions in operation to lower the temperature without allowing the cabin to cool down completely. The heating must be switched on to activate ECO mode. It is not possible to activate ECO mode if HOT mode is on.

ECO mode can be activated as follows:

- From the main menu. ► Switching on ECO mode from the main menu, [EN-39](#)
- Using a push button that is available as an option (recommended).

ECO mode can be deactivated as follows:

- It is switched off automatically once the period of time set in the service menu expires. A runtime must be defined in the service settings for this. See 6.1.13 Setting the ECO runtime, [EN-97](#)
- From the main menu. ► Switching off ECO mode from the main menu, [EN-41](#)  
This option allows you to cancel ECO mode early even if a runtime has been pre-set.
- Using a push button that is available as an option (recommended).

## ► Switching on ECO mode from the main menu

1 Tap the image for the heater that is switched on.

2  : Select and confirm.

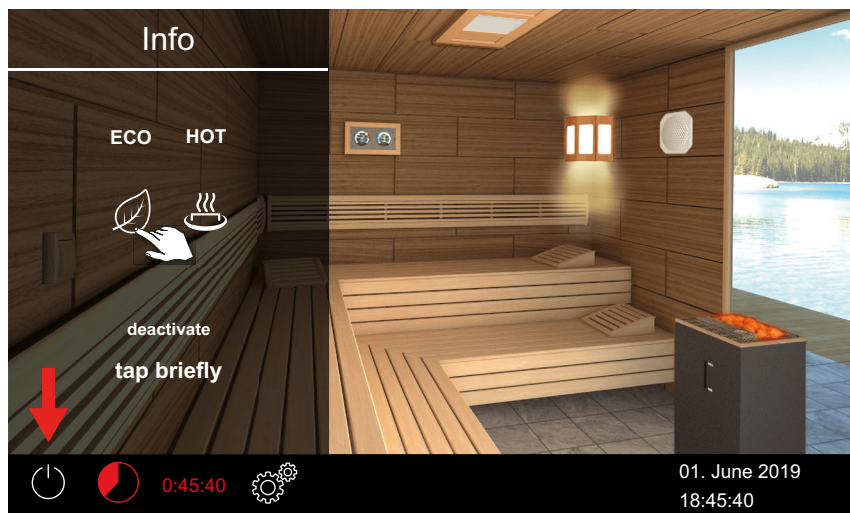

 Example: Single installation

ECO mode is activated. The ECO icon flashes in the status bar.



- ① When the ECO function is on, the fan is switched off and the ECO elapsed time and auto-stop time are displayed in alternation.
- ① Use the Info menu to check the current temperature during the ECO runtime. ► Checking the ECO temperature, [EN-40](#)

## Operation

In a multi-cabin installation, the ECO mode of the cabin is shown.

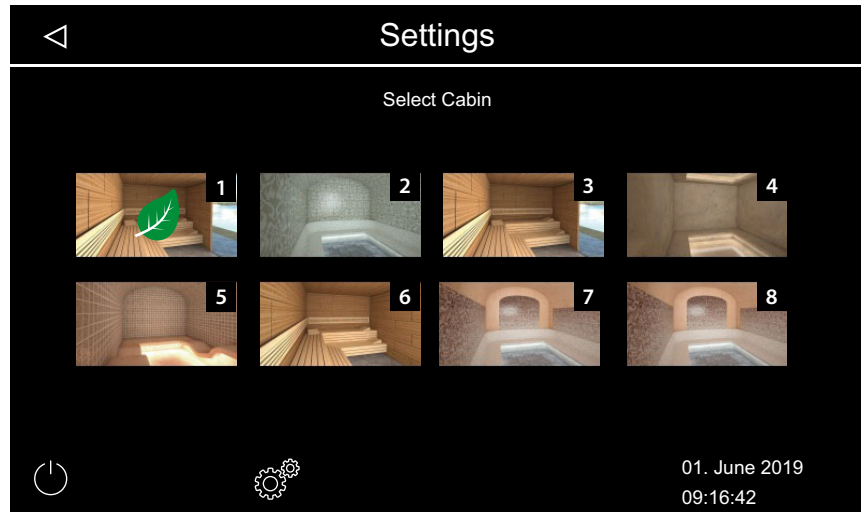

► **Checking the ECO temperature**

- 1 Tap the temperature/humidity image.



🖼 Example: Single installation





① The target temperature for the ECO temperature is displayed in green.

### ► Switching off ECO mode from the main menu

1 Tap the image for the heater that is switched on.

2  : Select and confirm.

ECO mode is switched off. The heating is started up again as defined in the settings.

## 5.4.7 Switching on HOT mode

This setting is available only in Finnish mode. It allows you to start operation at a higher temperature in order to heat the sauna stones to 115°C before and/or during an infusion phase and keep them hot.

HOT mode can be configured in the service menu so that it regularly starts and stops automatically.

See 6.1.12 HOT function, [EN-95](#)

HOT mode can be activated manually as follows:

- From the main menu. ► Starting HOT mode from the main menu, [EN-42](#)
- Using a HOT button that is available as an option.

HOT mode is ended as follows:

- It is switched off automatically once the period of time set in the service menu expires. The HOT function must be configured accordingly.
  - Configuring the HOT function, [EN-96](#).

HOT mode cannot be ended prematurely.

# Operation

## ► Starting HOT mode from the main menu

- 1 Tap the image for the heater that is switched on.
- 2  : Select and confirm.



HOT mode is activated. The HOT icon flashes in the status bar.



ⓘ When the HOT function is on, the HOT elapsed time and auto-stop time are displayed in alternation.

In a multi-cabin installation, the HOT mode of the cabin is shown.

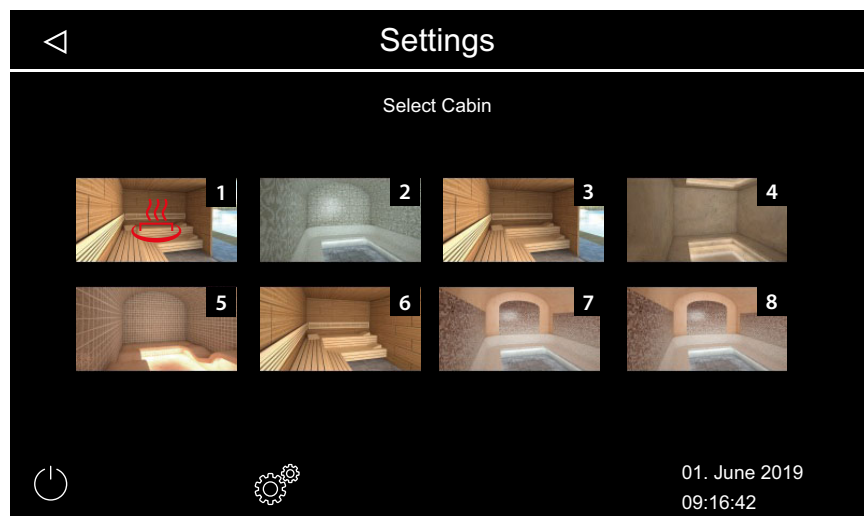

### 5.4.8 Switching potential-free contact on/off

You can switch an external device on and off manually with the EmoTouch 3 control unit. To do this, you must set the switching of the potential-free contact on/off in the service settings to manual on the display.

#### ► Switching potential-free contact on/off

- 1 Tap the image for potential-free contact.



**a)** Off: Switch position down

**b)** On: Switch position up

① If the image for potential-free contact is not displayed, contact your retailer or installation technician.

① See 6.1.6 Setting the potential-free contact, [EN-87](#)

## 5.5 Advanced settings

Depending on the installation and private versus commercial use, open the advanced settings as follows:

- 5.5.1 Advanced settings – single installation, [EN-45](#)
- 5.5.2 Advanced settings – multi-cabin installation, [EN-46](#)

The advanced settings are displayed with the following icons.



Language selection

- ▶ Changing the display language, [EN-51](#)



Time

- ▶ Setting the time, [EN-17](#)



Date

- ▶ Setting the date, [EN-17](#)



Screen saver

- ▶ Setting the time for screen saver activation, [EN-52](#)



Standby

- ▶ Setting the time for standby mode activation, [EN-53](#)



Operational lock/child lock

- ▶ Entering the PIN for the operational lock/child lock and activating it, [EN-55](#)



Display brightness

- ▶ Setting the contrast, [EN-56](#)



Holiday cottage mode

- ▶ Entering the PIN for holiday cottage mode and activating it, [EN-58](#)



Operating data

- Chapter 5.5.9 Operating data, [EN-59](#)



Display manufacturer contact data



Auto stop (heating period)

- ▶ Setting auto-stop for the heating period, [EN-62](#)



Timer

- ▶ Setting a one-time heating period, [EN-65](#),
- ▶ Setting the period for the first recurring heating period, [EN-70](#)





Coloured light coupling

- ▶ Coupling the coloured light to the heating, [EN-76](#)

### 5.5.1 Advanced settings – single installation

The advanced settings can be opened as follows in a single installation:

- ▶ Opening cabin settings in private use,  EN-45
- ▶ Opening general settings in commercial use,  EN-45

#### ▶ Opening cabin settings in private use

- 1 Tap .

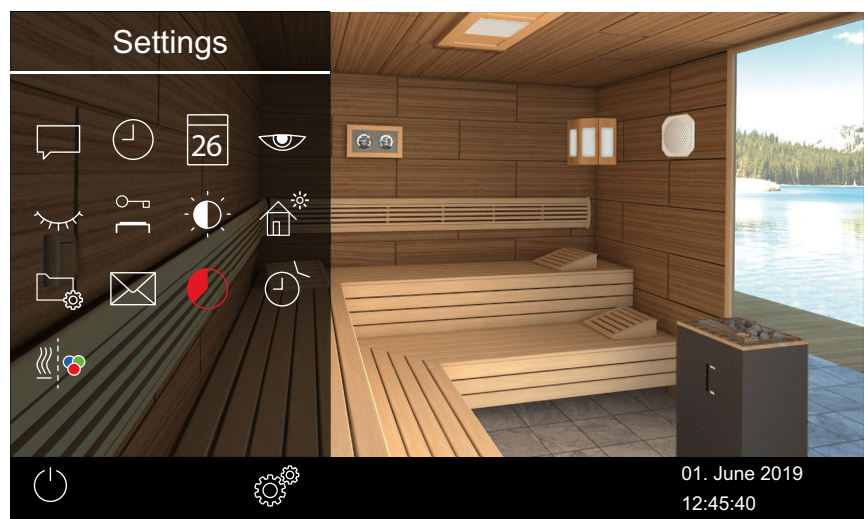

 Example: Advanced cabin settings

For a single installation, all setting options are displayed in a sub-menu.

#### ▶ Opening general settings in commercial use

- 1 Press and hold  for 3 seconds.





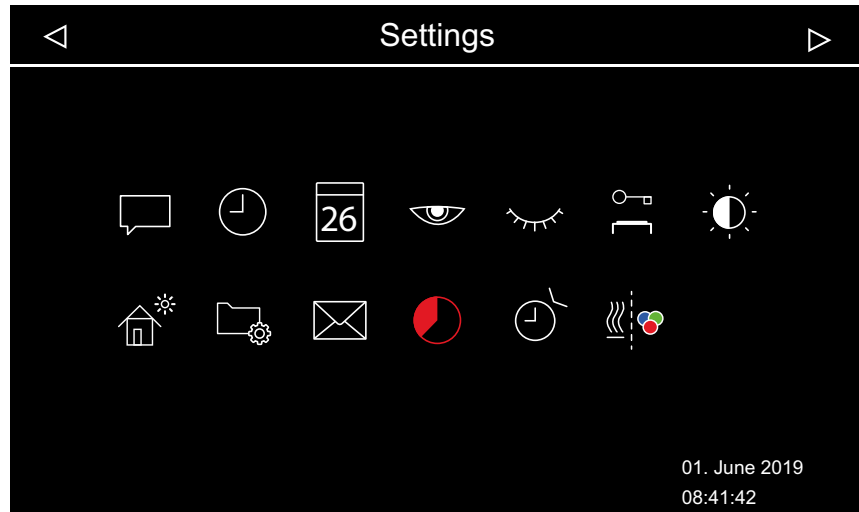

- 2 Enter code **5645**.



 Example: Single installation – general settings

### 5.5.2 Advanced settings – multi-cabin installation

Carry out the following steps to open the advanced settings in a multi-cabin installation:

- ▶ Private installation: opening the general settings,  EN-47
- ▶ Private installation: opening the cabin settings,  EN-47
- ▶ Commercial installation: opening the general settings,  EN-48
- ▶ Commercial installation: opening the cabin settings,  EN-49

Only the language can be changed in this way in a commercial multi-cabin installation. The selected language applies to all cabins.

In a multi-cabin installation, the following settings are defined for all cabins together:

- Language
- Time
- Date
- Screensaver
- Standby (sleep mode)
- Keypad lock
- Display brightness
- Holiday cottage mode
- Contact data

## ▶ Private installation: opening the general settings

- 1 Tap  in the cabin overview.

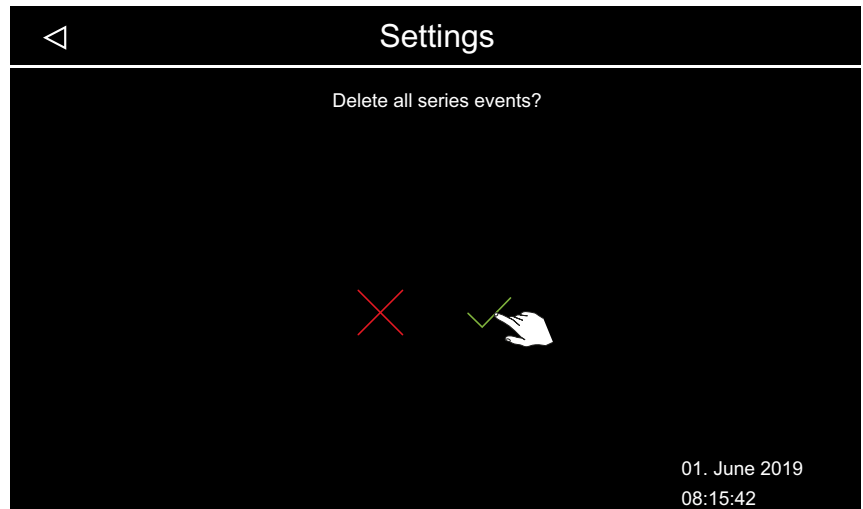

 Example: General settings in a private multi-cabin installation

## ▶ Private installation: opening the cabin settings

- 1 Select the cabin in the cabin overview.

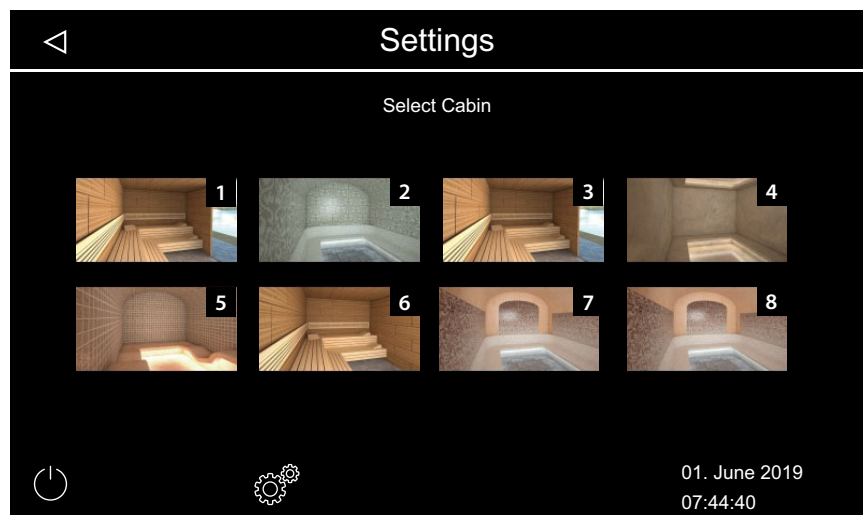

# Operation

- 2 Tap .

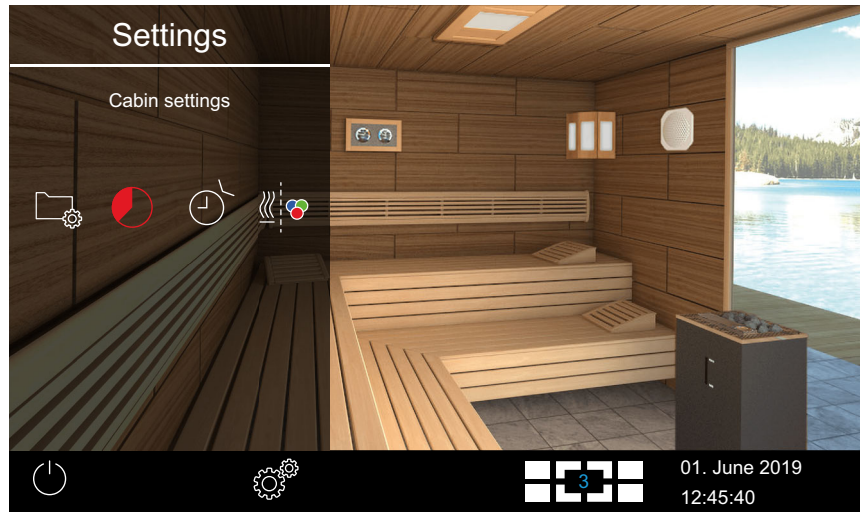

 Example: Cabin settings in a private multi-cabin installation

## ► Commercial installation: opening the general settings

- 1 Press and hold  for 3 seconds in the cabin overview.

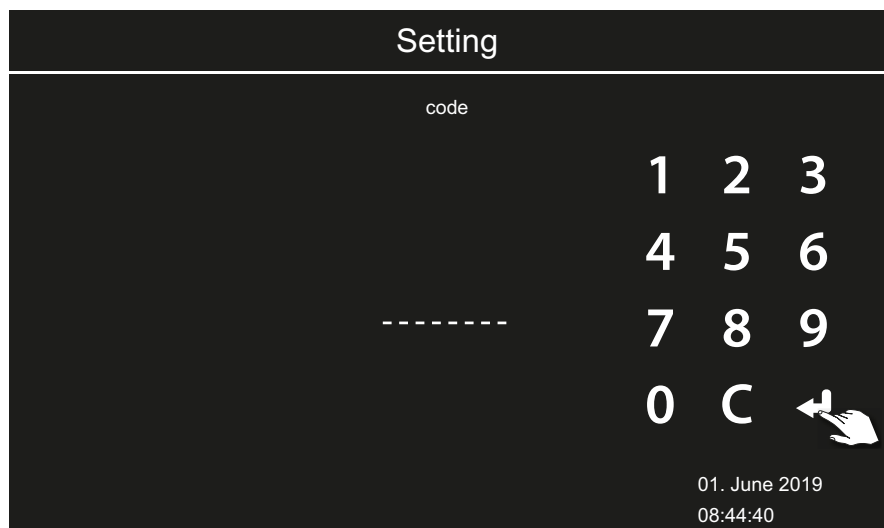



- 2 Enter code **5645**.

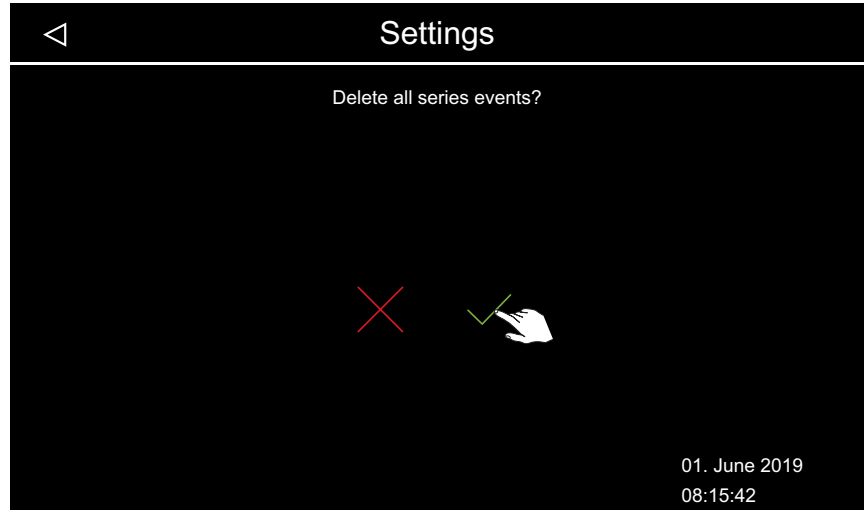

Example: General settings in a commercial multi-cabin installation

## ► Commercial installation: opening the cabin settings

- 1 Select the cabin in the cabin overview.

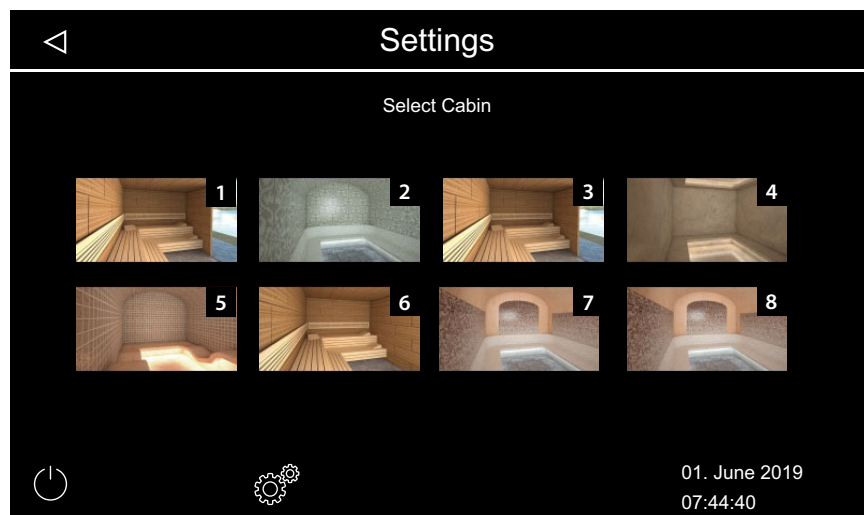

- 2 Press and hold  for 3 seconds.



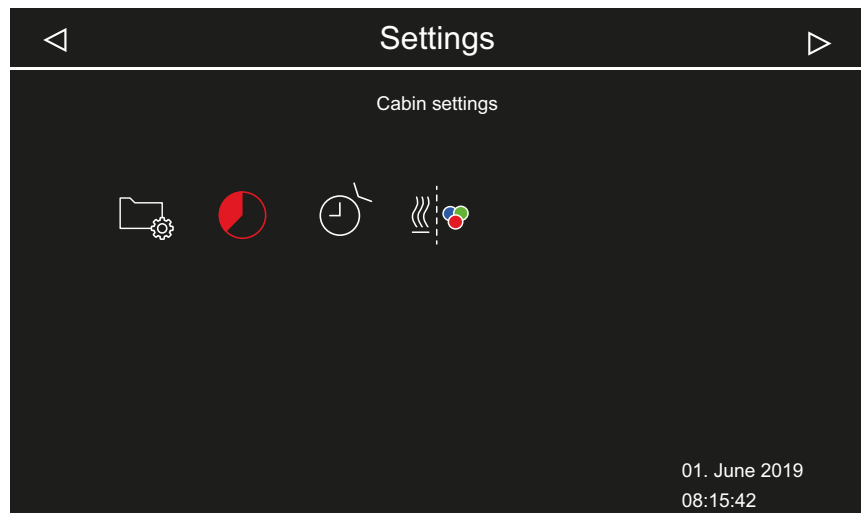

- 3 Enter code **5645**.



 Example: Cabin settings in a commercial multi-cabin installation

### 5.5.3 Language selection

#### ► Opening the advanced settings

- 1 Depending on the installation; see:
- a) 5.5.1 Advanced settings – single installation,  EN-45
  - b) 5.5.2 Advanced settings – multi-cabin installation,  EN-46
- ① With multi-cabin installations, you can change the language at each cabin. The set language applies to all cabins.

## ► Changing the display language

1 Tap  and confirm the selection.

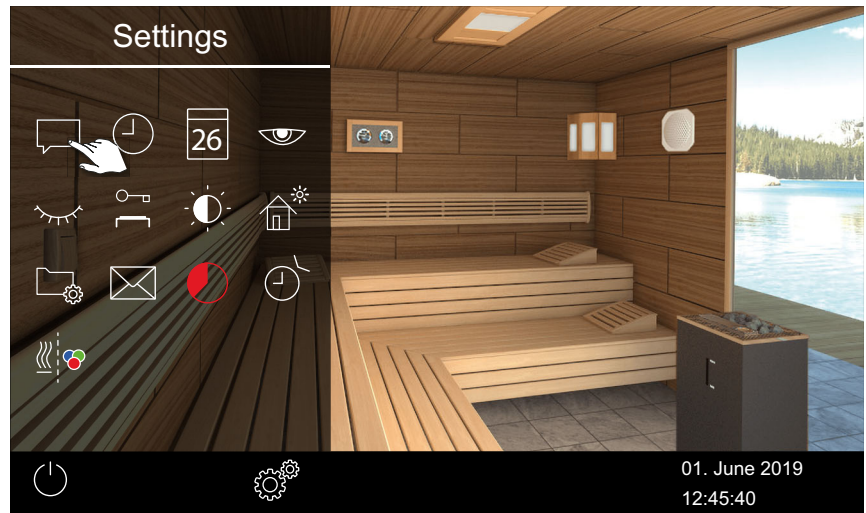

 Example: Single installation

2 Tap the desired language.



① The sub-menu closes. Texts on the display appear in the new language.

① With multi-cabin installations, the new language is adopted for all cabins.

### 5.5.4 Screen saver

You can set a time after which the EmoTouch 3 screen saver appears on the display.

#### ► Setting the time for screen saver activation

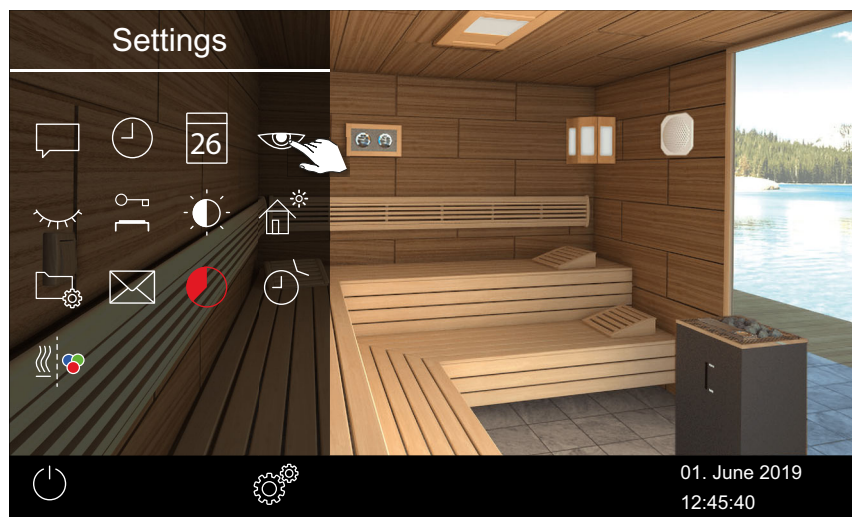

- 1 Open the advanced settings.
  - ① See 5.5 Advanced settings, EN-44
  - ① The setting for a single installation is shown in this example.
- 2 Tap  and confirm the selection.

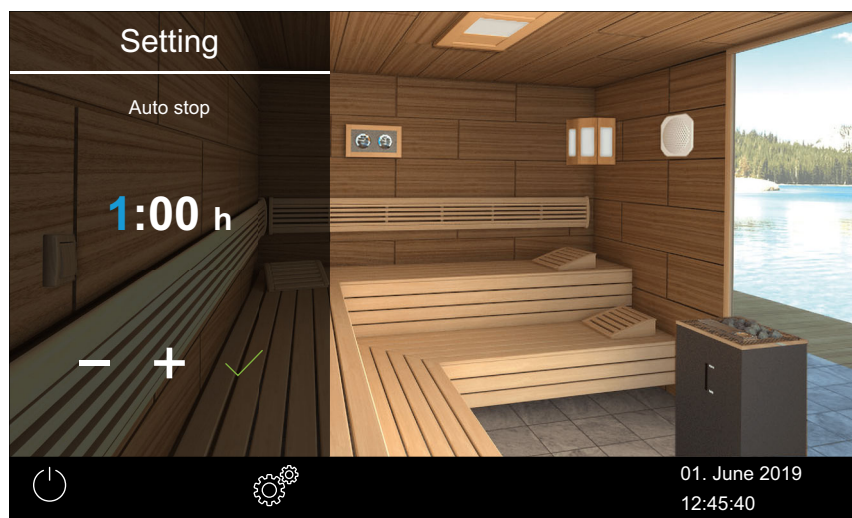

- 3 Press  and  to set the time in hours.



① The active place value appears in blue.

- 4 Tap  and confirm the selection.
- 5 Press  and  to set the time in minutes.

- 6 Tap  and confirm the selection.
  - The time is saved. The home screen with date and time is displayed as the screen saver.

## 5.5.5 Standby mode

This setting allows you to define the amount of time after which the control unit switches from the screen saver to standby mode. This function may be used only if heating is off. In standby mode, the display is completely black.

Tap on the display to end standby mode.

### ► Setting the time for standby mode activation

- 1 Open the advanced settings.
  - ① See 5.5 Advanced settings, EN-44
  - ① The setting for a single installation is shown in this example.
- 2 Tap  and confirm the selection.

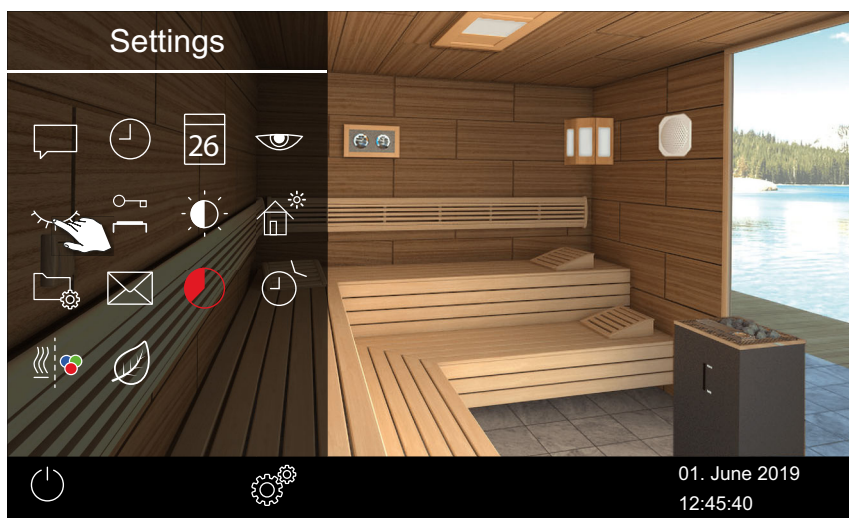

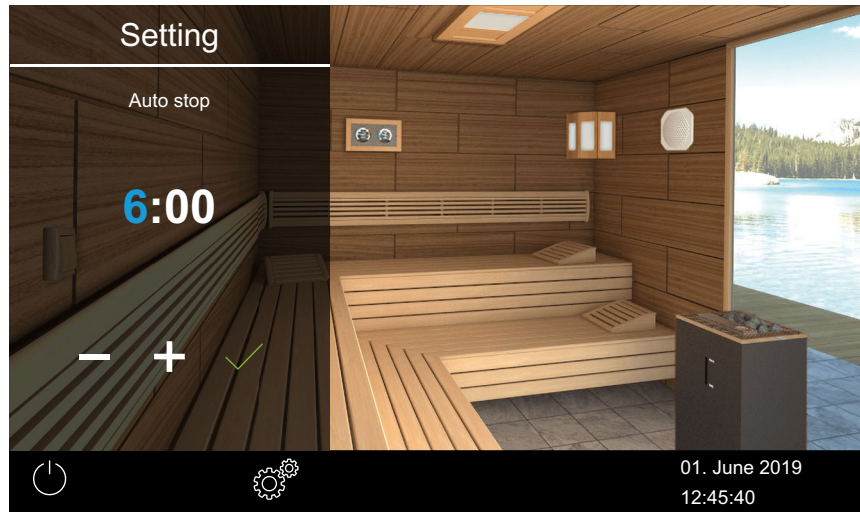

# Operation

- 3 Press **+** and **-** to set the time in hours.





ⓘ The active place value appears in blue.

- 4 Tap  and confirm the selection.
- 5 Press **+** and **-** to set the time in minutes.
- 6 Tap  and confirm the selection.
- The time is saved. In standby mode, the display is completely black.

## 5.5.6 Operational lock/child lock

You can lock the system to prevent unauthorised access. To do so, you must enter a PIN to lock the system so it cannot be operated.

You may choose the PIN. It must contain 4–8 digits. It is no longer possible to operate the system if you lose the PIN.

- ▶ Entering the PIN for the operational lock/child lock and activating it,  EN-55
- ▶ Deactivating the operational lock/child lock,  EN-56

### NOTICE

#### No access to the control unit

The control unit cannot be used if the PIN is not known.

- ▶ Save the PIN in a safe place.
- ▶ Contact your retailer or EOS Service if you lose your PIN.

## ► Entering the PIN for the operational lock/child lock and activating it

- 1 Open the advanced settings.
  - ① See 5.5 Advanced settings, EN-44
  - ① The setting for a single installation is shown in this example.
- 2 Tap  and confirm the selection.

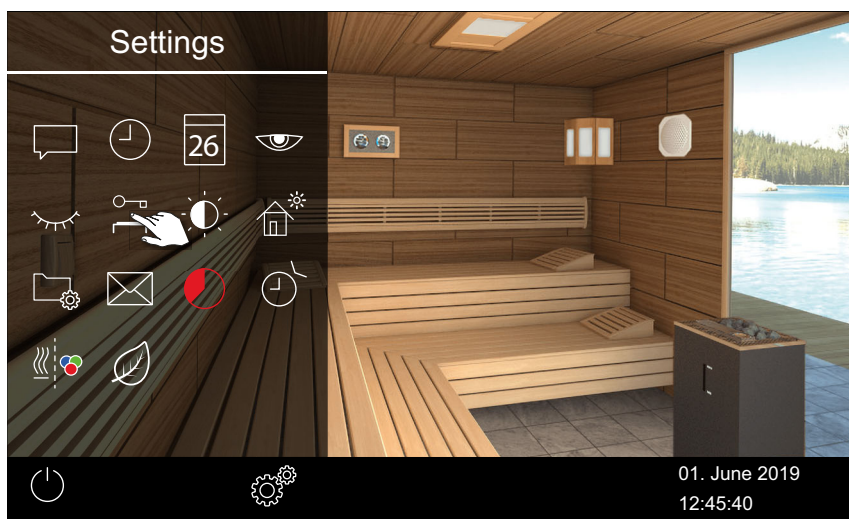

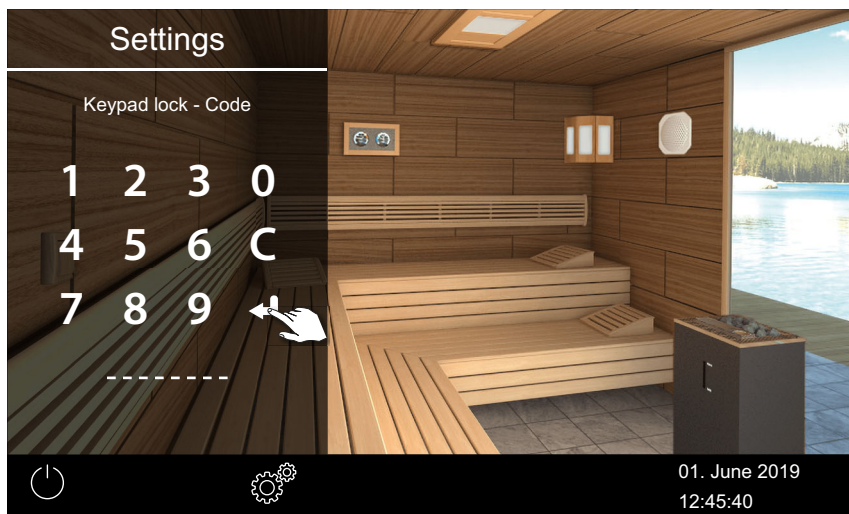

- 3 Enter the PIN and confirm.



- ① The display switches to the start screen and is locked.
- ① In this mode, it is only possible to switch off the heat if it is running and switch on the lighting. You must enter the PIN to use any of the other functions.

# Operation





## ► Deactivating the operational lock/child lock

- 1  : Select and confirm.
- 2  : Select and confirm.
- 3 Enter the PIN and confirm.  
 The display switches to the standby screen. All functions are available again.

## 5.5.7 Display brightness

You can adjust the display's brightness to accommodate environmental conditions.

### ► Setting the contrast

- 1 Open the advanced settings.  
 See 5.5 Advanced settings,  EN-44  
 The setting for a single installation is shown in this example.
- 2 Tap  and confirm the selection.

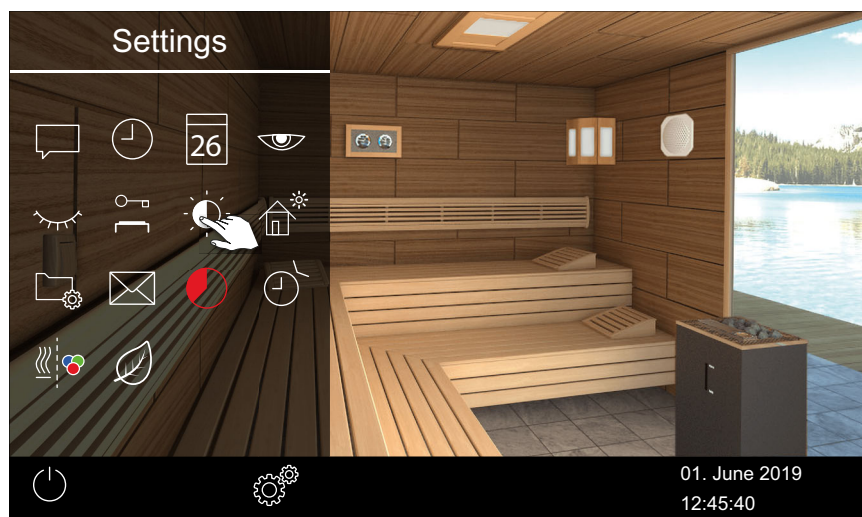



- 3 Move the slider to the desired light intensity in %.



- ① The brightness is adjusted immediately.

## 5.5.8 Holiday cottage mode

You can limit access to the settings with a PIN. The following (direct) settings are excluded from being blocked:

- Sauna heater on/off
- Light on/off, dim light
- Setting the temperature
- Retrieve temperature/humidity values
- Manual switching of potential-free contact
- Music control (for connected sound module)
- Coloured light control (for connected coloured light module)
- For multi-cabin installations - selection of single cabins

All other settings are locked. The corresponding icons are hidden.

You may choose the PIN. It must contain 4–8 digits. It is no longer possible to operate the system if you lose the PIN.

- ▶ Entering the PIN for holiday cottage mode and activating it, [EN-58](#)
- ▶ Deactivating holiday cottage mode, [EN-59](#)

### NOTICE

#### No access to the control unit

The control unit cannot be used if the PIN is not known.

- ▶ Save the PIN in a safe place.
- ▶ Contact your retailer or EOS Service if you lose your PIN.

# Operation

## ► Entering the PIN for holiday cottage mode and activating it

- 1 Open the advanced settings.
  - ① See 5.5 Advanced settings, EN-44
  - ① The setting for a single installation is shown in this example.
- 2 Tap  and confirm the selection.



- 3 Enter the PIN and confirm.



- ① The display switches to the start screen and is locked.

## ► Deactivating holiday cottage mode

- 1 Open the advanced settings.
  - ① See 5.5 Advanced settings, [EN-44](#)
- 2 Enter the PIN and confirm.
  - The display switches to the standby screen. All functions are available again.

## 5.5.9 Operating data

You can retrieve your control unit's current firmware version and device number for the control panel, the modules, and the service interval.

- Retrieving the firmware version and unit serial number, [EN-59](#)
- Retrieving the next service date, [EN-60](#)

You can write the operating data to a memory card and send it to your service technician if needed. See the chapter on 6.2.3 Exporting the operating data, [EN-107](#).

### ► Retrieving the firmware version and unit serial number

- 1 Open the advanced settings.
  - ① See 5.5 Advanced settings, [EN-44](#)
  - ① The setting for a single installation is shown in this example.
- 2 Tap  and confirm the selection.

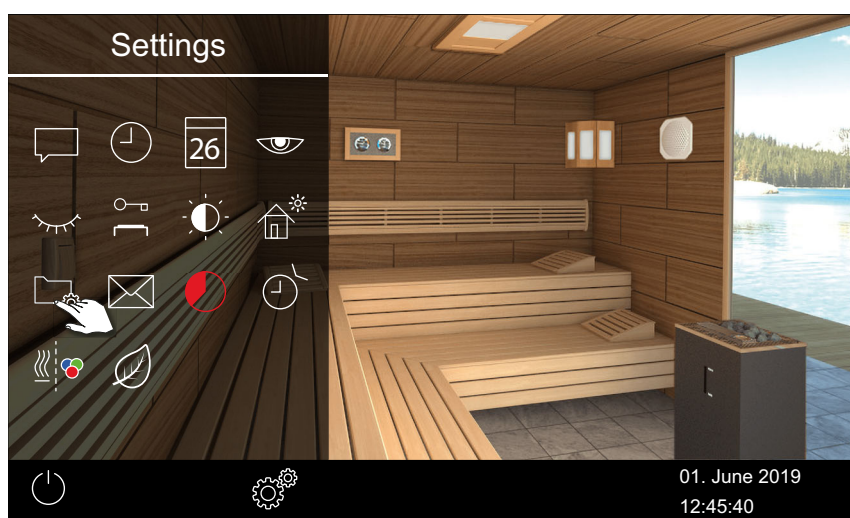

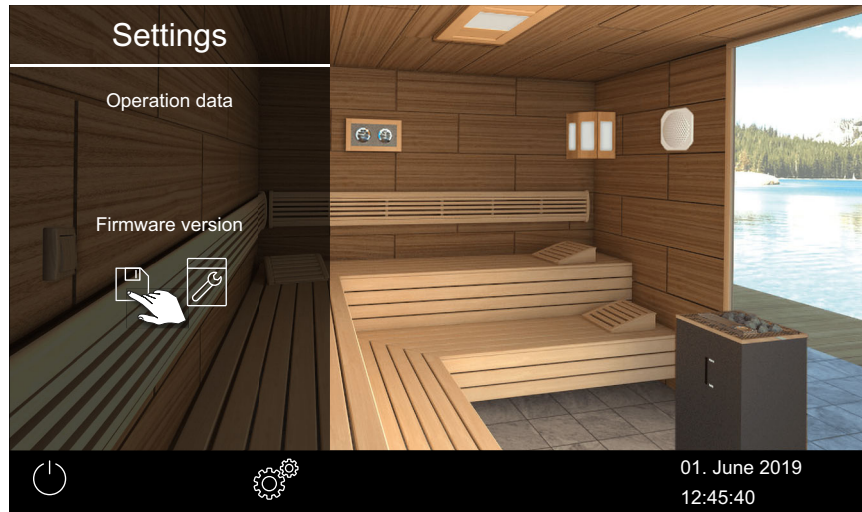

# Operation

- 3 Tap  and confirm the selection.



The current status of each module is displayed. The serial number is displayed, e.g. 021000182.

## ► Retrieving the next service date

- 1 Open the advanced settings.
  - ① See 5.5 Advanced settings,  EN-44
  - ① The setting for a single installation is shown in this example.
- 2 Tap  and confirm the selection.

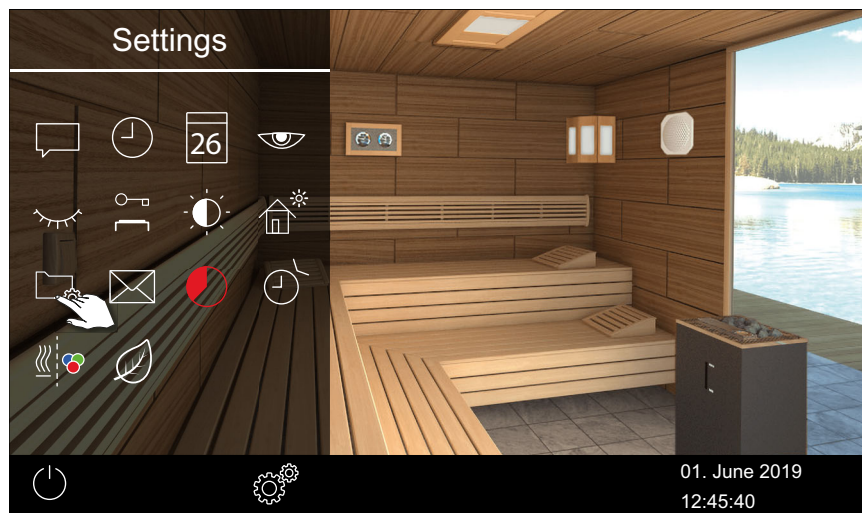

- 3 Tap  and confirm the selection.

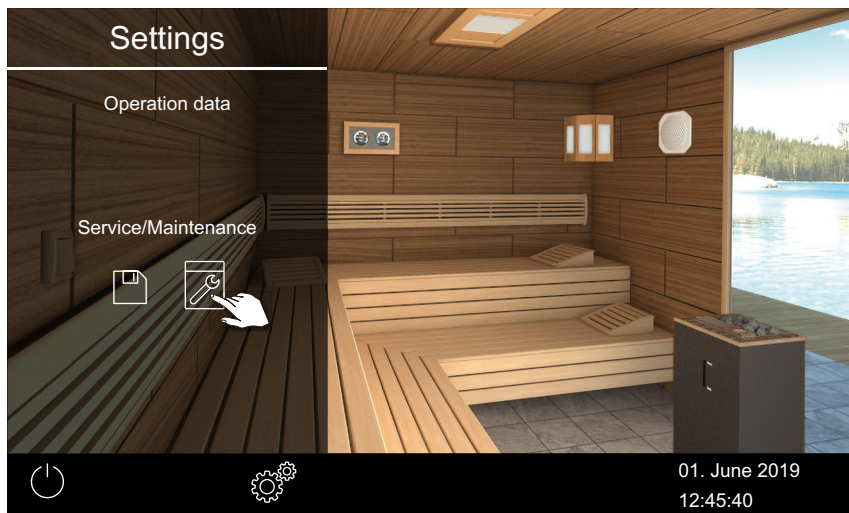

- The time in hours that remains until the next servicing is displayed.

The following values are set for the service intervals by the factory:

- Private use: 500 hours
- Commercial use: 2500 hours

### 5.5.10 Heating period – auto stop

You can set a heating period for the sauna heater.

If the system is used in a private setting, the heating period is limited to 6 hours.

You can set the heating period as follows in commercial operation:

- max. 12 h if the cabin is not being monitored.  
max. 18 h if the cabin is being monitored.
- unlimited heating period if the cabins are being monitored. Please observe the local statutory intermission times.



If the cabin is operated in humidity mode, the drying program starts once humidity mode is switched off. This program continues to run the sauna heater for up to 30 minutes. The runtime of the drying program can be changed in the basic setup.

See 6.1.10 Post-heating time,  EN-93.

### ► Setting auto-stop for the heating period

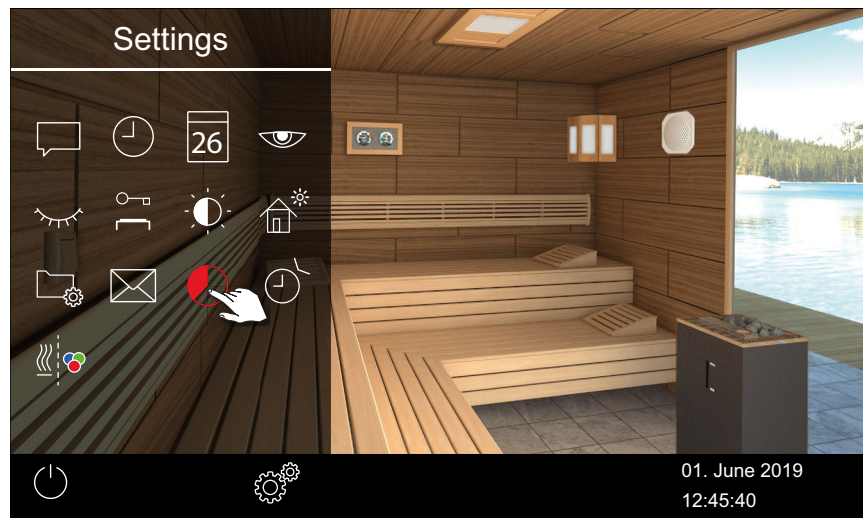
- 1 Open the advanced settings.
  - ① See 5.5 Advanced settings, EN-44
  - ① The setting for a single installation is shown in this example.
- 2 Tap  and confirm the selection.



- 3 Set the desired heating period in hours and minutes by pressing  and , and then confirm.
  - ① The heating period can be set in operation mode. The heating period in progress is not altered by this. The new heating period starts only after heating is switched on again.

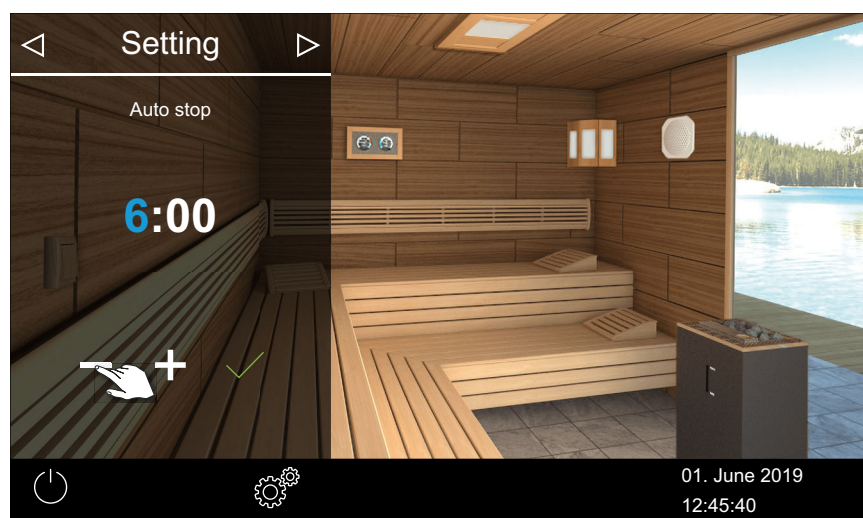

- ① The active place value appears in blue.
- ① If the system is used in a private setting, the heating period is limited to 6 hours. Therefore, it is only possible to decrease the heating period. If the system is used commercially, you must observe the statutory intermission times.

- 4 Tap  and confirm the selection.
  - ① After switching on the sauna heater, the remaining runtime is displayed as a countdown timer in the lower left. It indicates how long the sauna heater will remain switched on.



☑ Note that after the set time elapses in humidity mode, the fan switches on to dry the system. You can set the fan and fan runtime in the service menu.

📖 Fan settings:

- ▶ Activating or deactivating the fan, [EN-89](#)
- ▶ Setting the post-cycle period for drying the cabin, [EN-90](#)

## 5.5.11 Automatic start time

This function allows you to set the automatic start time up to 24 hours in advance.

- ▶ Setting the automatic start time, [EN-63](#)
- ▶ Deleting timer settings, [EN-65](#)

It is possible to set an automatic start time only if the sauna is equipped with a safety device that conforms to standards. This safety device must be confirmed during setup.

See ▶ Security settings, [EN-20](#).

### ▶ Setting the automatic start time

- 1 Open the advanced settings.
  - ① See 5.5 Advanced settings, [EN-44](#)
  - ① The setting for a single installation is shown in this example.

- 2 Tap  and confirm the selection.

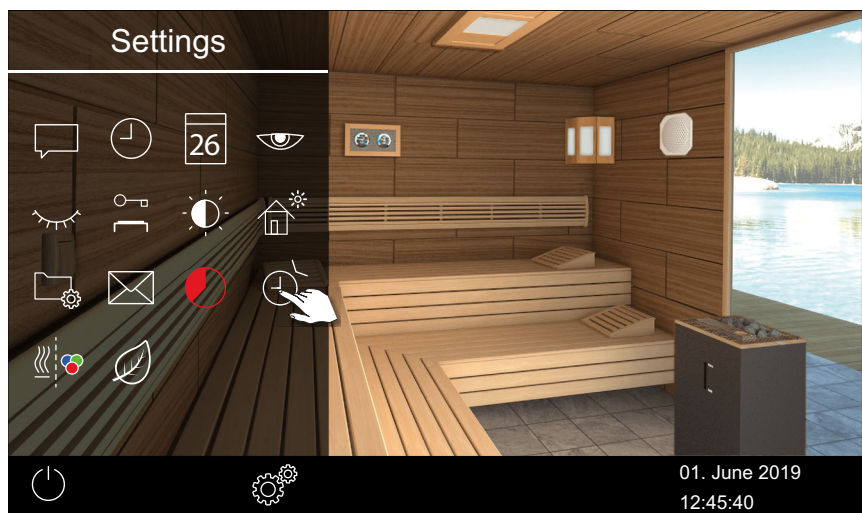





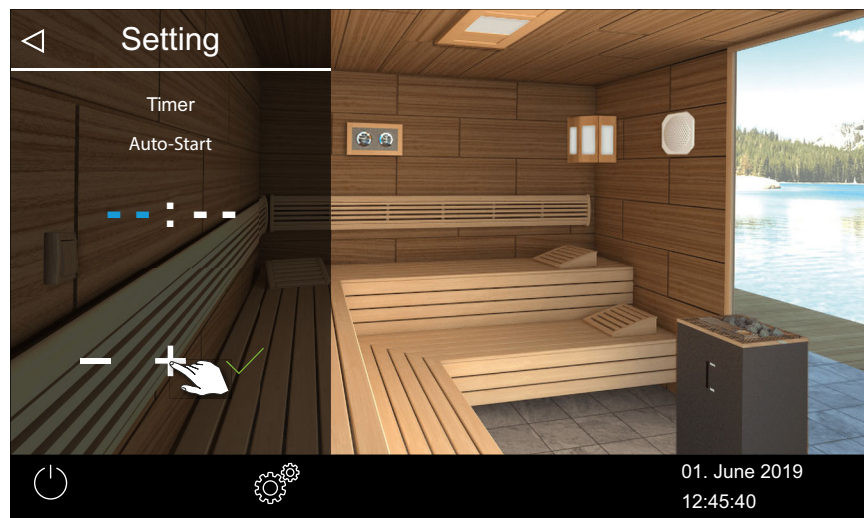

# Operation

3 Tap .



4 Confirm the selection.



- 5 Press  and  to set the time in hours.
  - ⓘ The active place value appears in blue.
  - ⓘ Pressing and holding the icon changes the value in increment mode.
- 6 Tap  and confirm the selection.
- 7 Press  and  to set the time in minutes.
- 8 Tap  and confirm the selection.
  - ☑ The time is saved. The timer icon is displayed in blue on the cabin image.



## ► Deleting timer settings

- 1 Open the sub-menu for auto start, as shown above.
  - Setting the automatic start time, [EN-63](#)
- 2 Set the time and/or date to --:--.
  - The timer settings are deleted.

## 5.5.12 One-time heating period

This function allows you to define a one-time heating period for a single day. The heating duration corresponds to the time set for auto stop; see ► Setting auto-stop for the heating period, [EN-62](#).

You can also set recurring heating periods for each cabin if the system is used commercially.

If you start the system manually within the set period of time, the heating period ends automatically at the set stop time. This makes it possible, for example, to start again quickly in timer mode after an interruption.

- Selecting the operating mode, [EN-18](#)
- Setting a one-time heating period, [EN-65](#)
- Deleting timer settings, [EN-68](#)

### ► Setting a one-time heating period

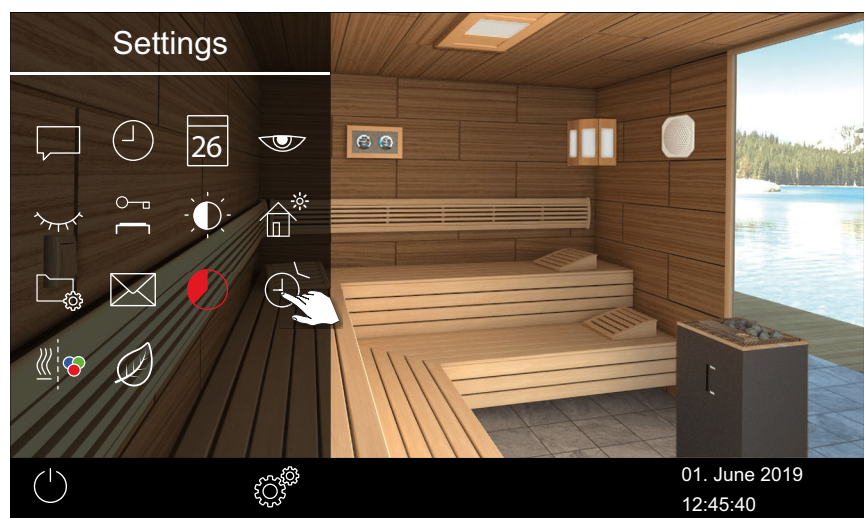

- 1 Open the advanced settings.
  - ① See 5.5 Advanced settings, [EN-44](#)
  - ① The setting for a single installation is shown in this example.
- 2 Tap  and confirm the selection.



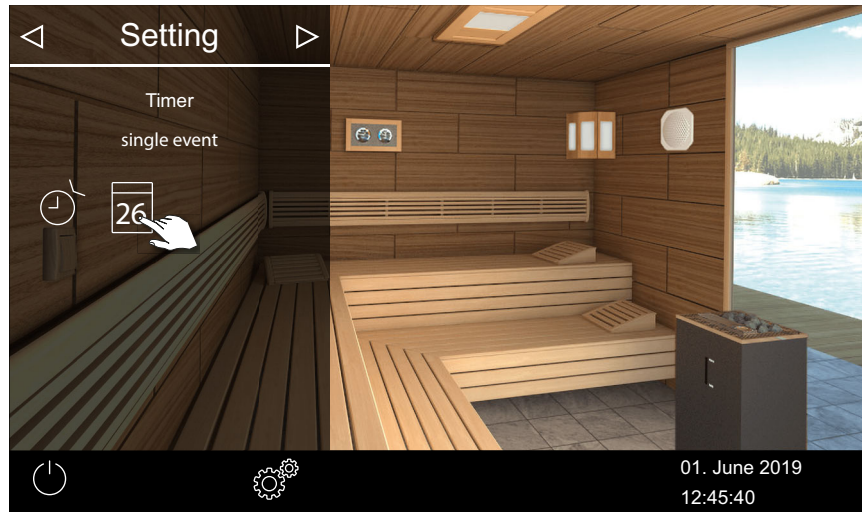

# Operation

- 3 Tap  and confirm the selection.

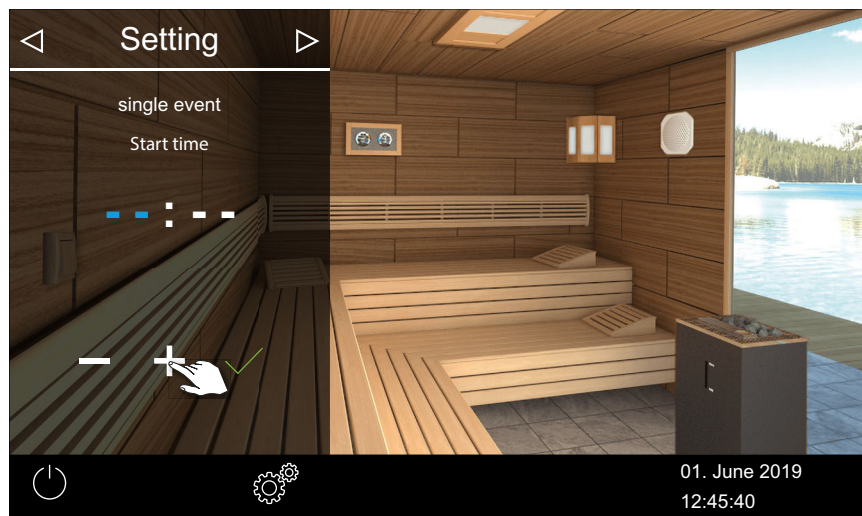

- 4 Press  and  to set the time in hours and minutes.



 The active place value appears in blue.

- 5 Tap  and confirm the selection.  
 The time is saved and the sub-menu for the date is shown.

- 6 Set the day, month, and year by pressing **+** and **-**.

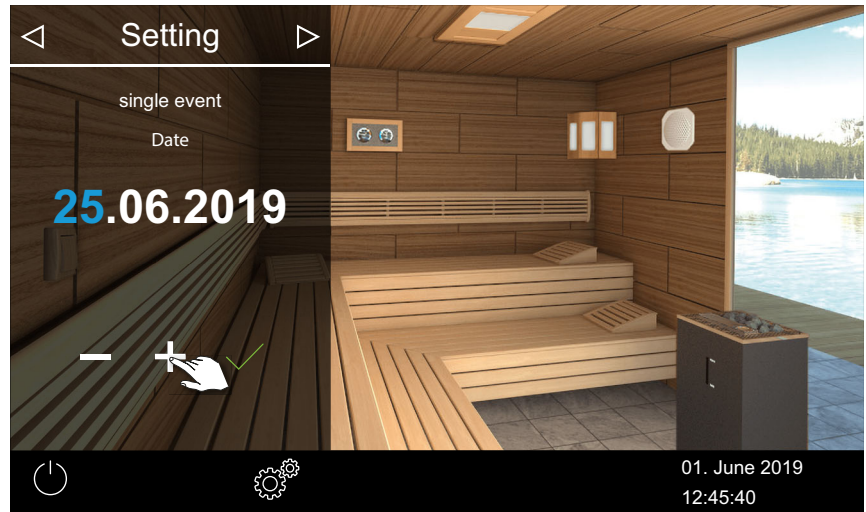

① The active place value appears in blue.

- 7 Tap  and confirm the selection.  
 The date is saved and the sub-menu for the temperature is shown.

- 8 Move the slider to the desired temperature.

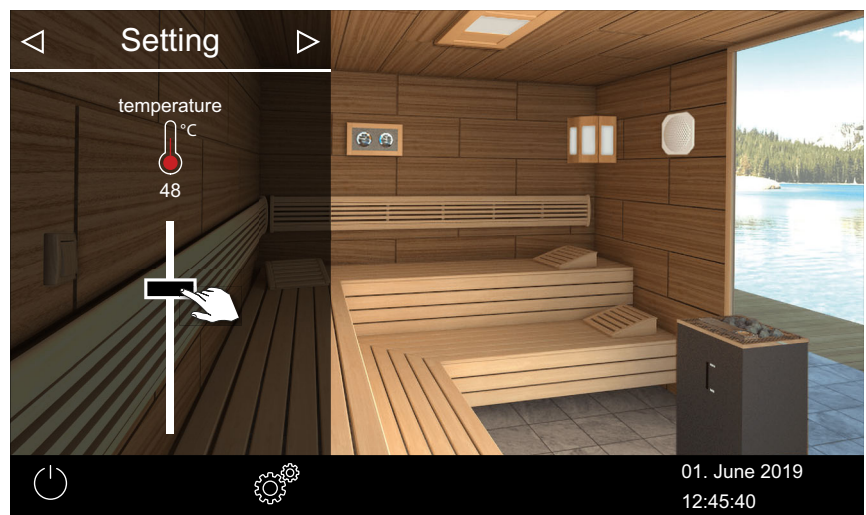

- 9 Tap  to close the sub-menu.  
 The settings are saved.



① A blue timer icon is displayed in the status bar next to the date. The date and time blink in blue.

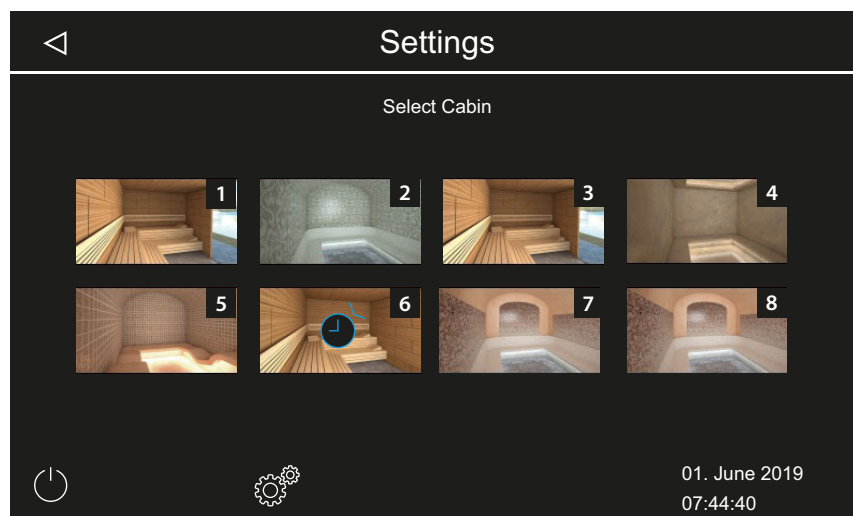

- ① With multi-cabin installations, the timer symbol on the cabin image are displayed in blue.
- ① The heating duration corresponds to the time set for auto stop; see ► Setting auto-stop for the heating period, EN-62.

#### ► Deleting timer settings

- 1 Open the sub-menu for one-time heating periods, as shown above.
- 2 Set the time and/or date to --:--.  
 The timer settings are deleted.

### 5.5.13 Recurring heating periods

The function is available only in cases of commercial operation.

A series of up to four programs is possible per weekday. You can set an individual start and stop time for each recurring heating period, as well as an individual temperature. In Bi-O mode you can set the temperature and humidity.

For example, you can set only one period for all days of the week and 2–3 additional heating periods on specific days of the week. These could be weekend days on which the sauna is often used.

Recurring heating periods in multi-cabin installations are set for each of the cabins individually. Please observe any applicable standards for the maximum heating period.

The following situations are displayed on the display:

- Time blinking in blue    The programmed cycle time is permitted, the timer is started.
- Time blinking in red    The programmed cycle time is not permitted, the timer does not start.  
Possible causes: Heating time limitation is exceeded or the required intermission time is not observed.

Defined recurring heating periods are displayed as follows:

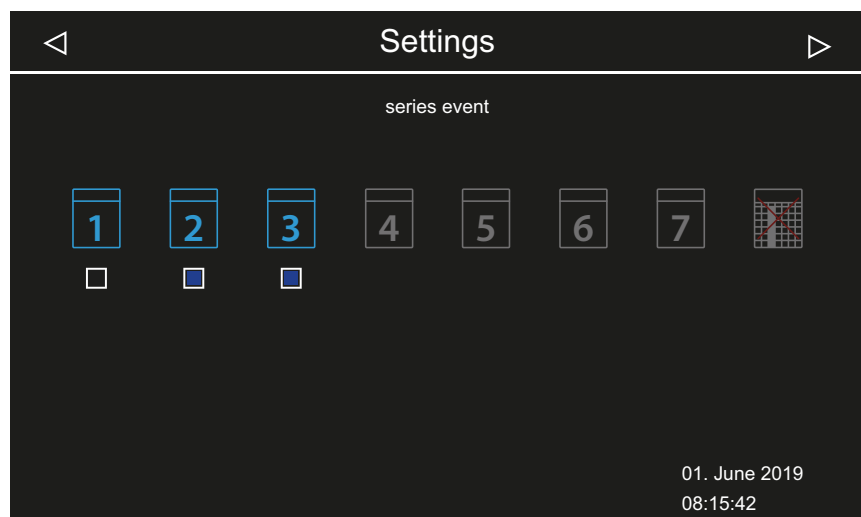

- Monday (1)                      Check box is black: Set period is deactivated. The cabin is not heated.
- Tuesday and Wednesday (2, 3)    Check box is blue: Set period is activated. The cabin is heated during the set periods.
- Weekdays 4–7                      No periods set.

- ▶ Setting the period for the first recurring heating period, [EN-70](#)
- ▶ Setting the second heating period in the series, [EN-73](#)
- ▶ Deleting the period in a series, [EN-74](#)
- ▶ Deleting all recurring heating periods, [EN-74](#)

**► Setting the period for the first recurring heating period**

- 1 Open the advanced settings.
  - ① See 5.5.2 Advanced settings – multi-cabin installation, [EN-46](#)
  - ① The setting for a commercial multi-cabin installation is shown in this example.
- 2 Tap  and confirm the selection.

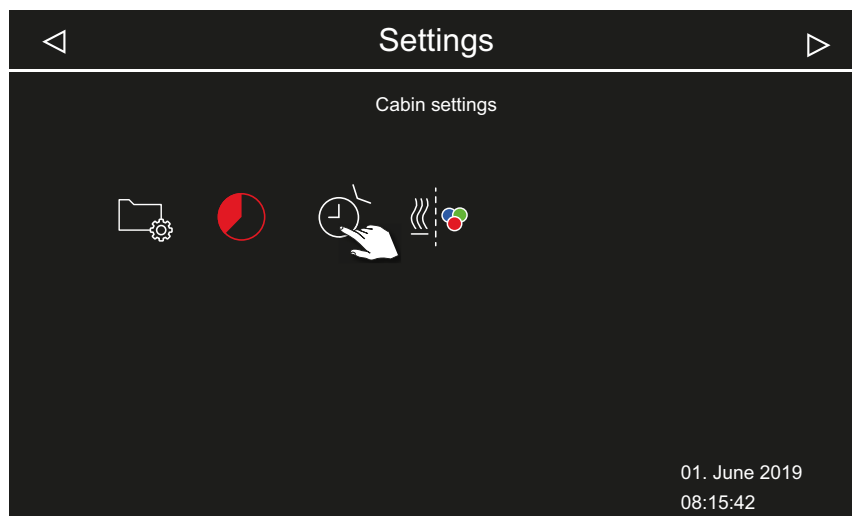

- 3 Tap  and confirm the selection.

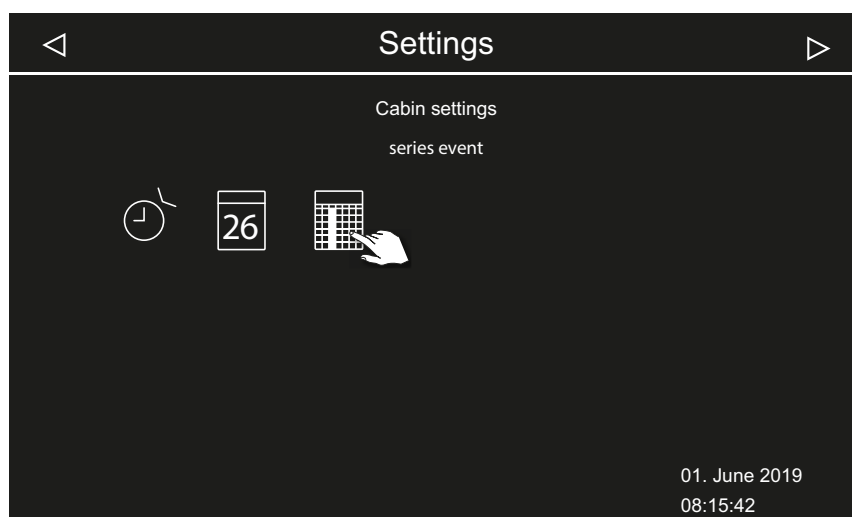

- 4 Tap the day of the week and confirm the selection.



- ① A series of four periods is possible per day of the week.

- 5 Tap the number for the first period of the series and confirm.

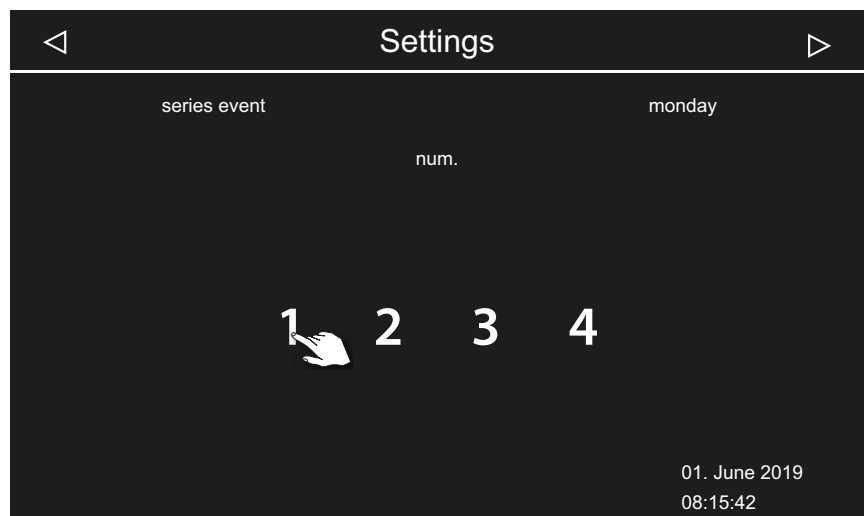

- ① Enter the start time and end time for each heating period.

## Operation

- 6 Set the start time with **+** and **-**, and then confirm by pressing **✓**.

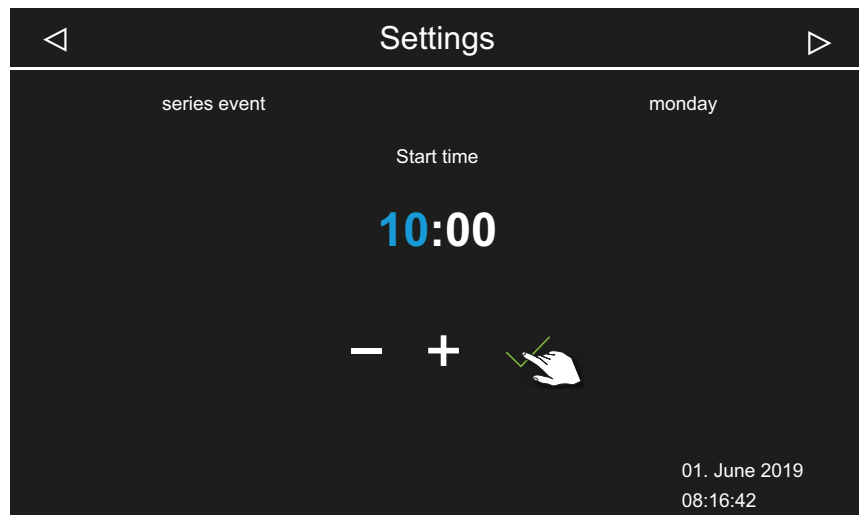

① The active place value appears in blue.

- 7 Set the end time with **+** and **-**, and then confirm by pressing **✓**.

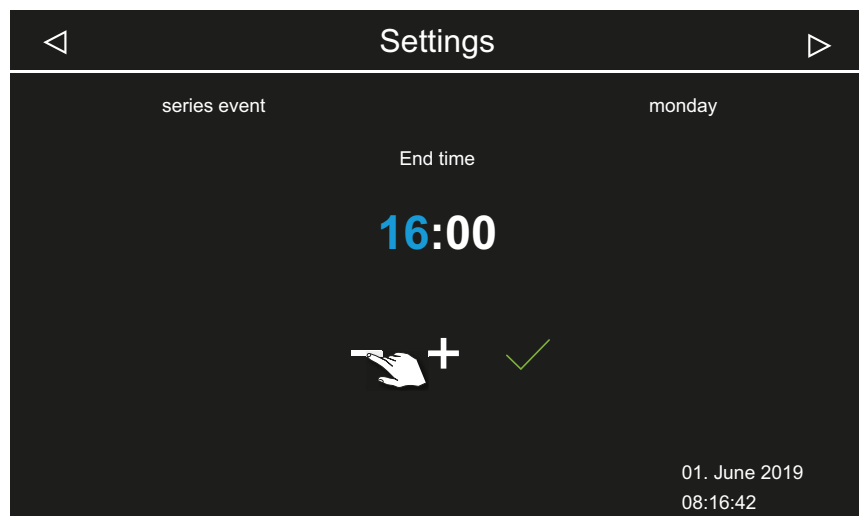



- 8 Set the desired temperature with the slider.

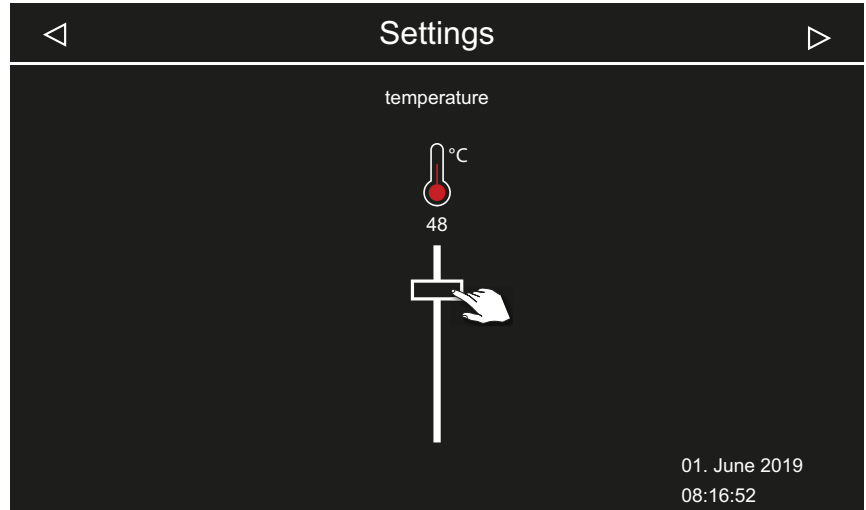

 Example of Finnish mode

- ① In Bi-O mode you can also set the humidity.
- This sets the first period of the series.

### ► Setting the second heating period in the series

- 1 Repeat the steps for the next heating period:

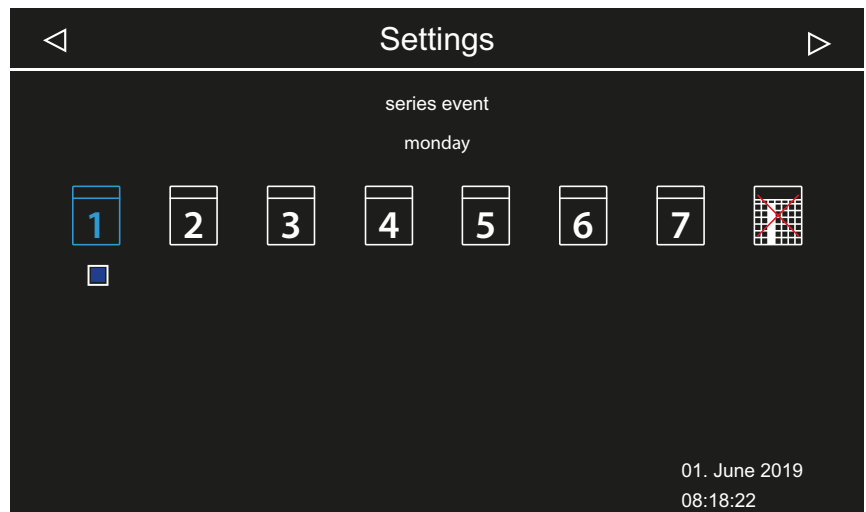

- ① Days of the week with a recurring heating period are displayed in blue. Active series are indicated by a blue check box.
- a) Choose the recurring heating period.
- b) Choose the day of the week.
- c) Choose the next number. Blue numbers already have a heating period defined.

d) Set the start time and end time.

e) Set the temperature.

### ► Deleting the period in a series

1 Open the advanced settings.

① See 5.5 Advanced settings, EN-44

② In the multi-cabin installation, open the advanced settings for one cabin.

2 Tap  and confirm the selection.

3 Tap the day of the week and confirm the selection.

4 Tap the heating period number and confirm the selection.

5 Set the start time to --:-- and confirm the setting.

① This deletes the specific heating period for the current series. All other defined heating periods remain set.

6 Repeat the step as needed for additional start times in the series.

① When all heating periods on a given day of the week are deleted, the day appears in white again on the display.

### ► Deleting all recurring heating periods

1 Open the advanced settings.

① See 5.5 Advanced settings, EN-44

② In the multi-cabin installation, open the advanced settings for one cabin.

2 Tap  and confirm the selection.

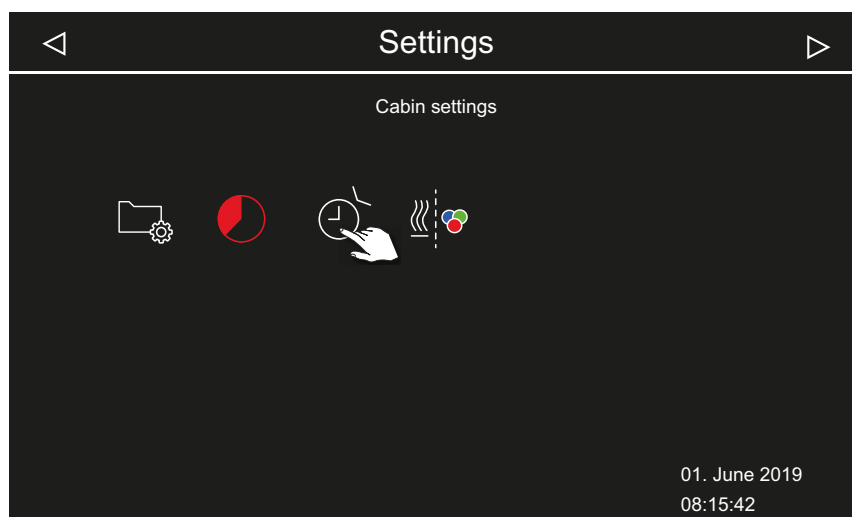

3 Tap  and confirm the selection.

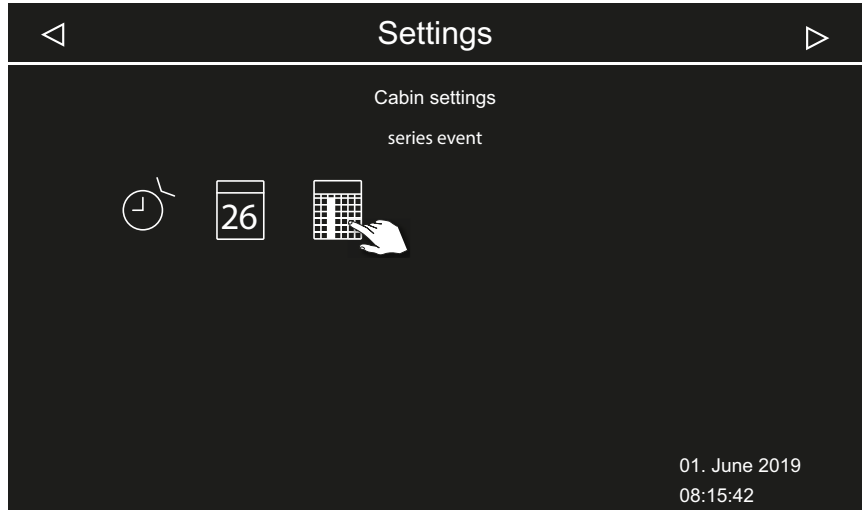

4 Tap  and confirm the selection.

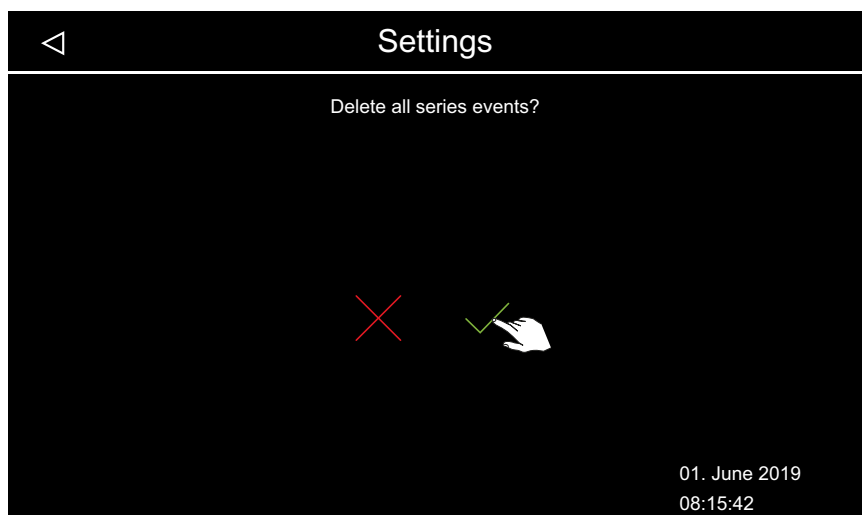
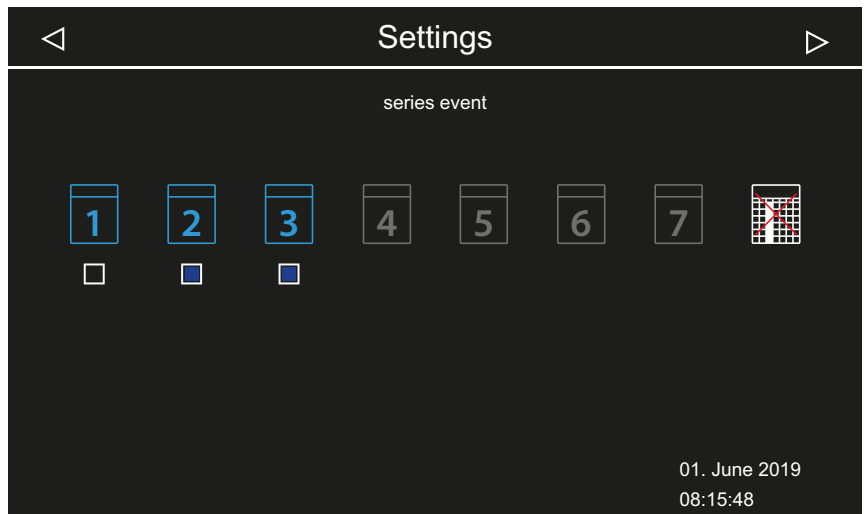

- 5 Confirm the prompt with .
  - ⓘ All series with all defined heating periods are deleted.

### 5.5.14 Coloured light coupling

Each cabin may be equipped with a coloured light system as an option. This coloured light system can be coupled to the heating so that it starts automatically when the sauna heater is switched on. Settings for the coloured light itself are described in the installation instructions for the coloured light module.

- ▶ Coupling the coloured light to the heating, [EN-76](#)
- ▶ Decoupling the coloured light from the heating, [EN-78](#)

#### ▶ Coupling the coloured light to the heating

- 1 Open the advanced settings.
  - ⓘ See 5.5 Advanced settings, [EN-44](#)
  - ⓘ The setting for a single installation is shown in this example.
- 2 Tap  and confirm the selection.

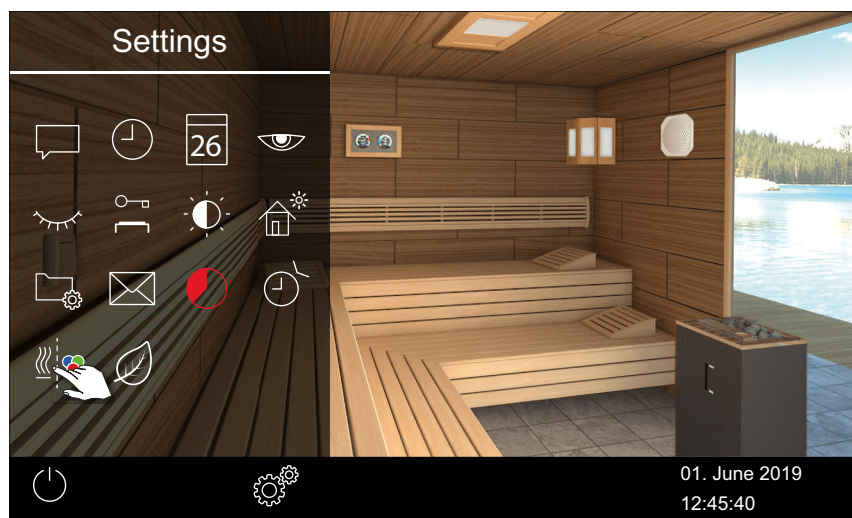

3 Tap  and confirm the selection.



The coloured light is coupled to the heating.

# Operation

## ► Decoupling the coloured light from the heating

- 1 Open the advanced settings.
  - ⓘ See 5.5 Advanced settings, EN-44
  - ⓘ The setting for a single installation is shown in this example.
- 2 Tap  and confirm the selection.



- 3 Tap  and confirm the selection.



- Coloured light and heating are not coupled.

## 5.6 Error messages

Error messages are shown on the display in plain text. When an error message appears, the heating period in progress is interrupted.



In a multi-cabin installation, the malfunction is shown in the status bar of the cabin overview. Error message details are displayed in the affected cabin.

Error – error message	Reason	Solution
Display is blank	No power.	Check fuses.
	Switch-off switch is switched off.	Check that the switch is in the correct position.
	No connection between the control panel and the power unit.	Check the cable for a secure connection.
Temperature sensor fault	No connection to the temperature sensor.	Check the cable and connections.
	Sensor is defective.	Replace the sensor.
No heat.	No connection.	Check the cable and connections (broken cable, loose connection, etc.).
	Safety temperature limiter triggered.	Safety temperature limiter may have been triggered by overheating in the cabin. Rectify the reason for overheating. Replace the safety temperature limiter fuse.
Water shortage	Not enough water in the vaporiser.	Refill water. Install automatic filling, if necessary.
	Malfunction when automatically filling water.	Check water supply. Clean the filter at the water supply connector if necessary.
	No water supply, water inlet valve clogged, blocked, or defective.	Clean the water inlet valve and check that it functions properly. Replace the water inlet valve if necessary.
No bus communication	Faulty connection to the control panel.	Check the cabling between the control panel and the power unit.
		Restart the control unit. Contact technical support.
Other errors	Software error.	Restart the control unit. Contact technical support.
Cabin image is displayed only in grey	Incorrect bus configuration.	
	Power unit not detected.	Check the cabin address.
	Power unit is connected to the wrong jack in the control panel.	Check the cabin address and connection in the control panel.
	Multiple power units are programmed with the same address.	Check the cabin addresses. See Installation Instrukctions.

## 6

## Service settings

This chapter is intended for service technicians.

A description of the user interface and the common icons are found in the chapter entitled Operation, [EN-26](#).

### ⚠ CAUTION

#### Health risks

Incorrect settings can raise the cabin temperature to a level that is prohibited and extend the heating period to an impermissible amount of time.

This can lead to serious health risks or even death in persons with health impairments.

- ▶ Only trained personnel may change settings at the service level.
- ▶ Service level code (5349) should be given only to trained personnel.

### 6.1 Service level

Access to the service level is protected by a code.

The settings at this level must only be changed by trained personnel.

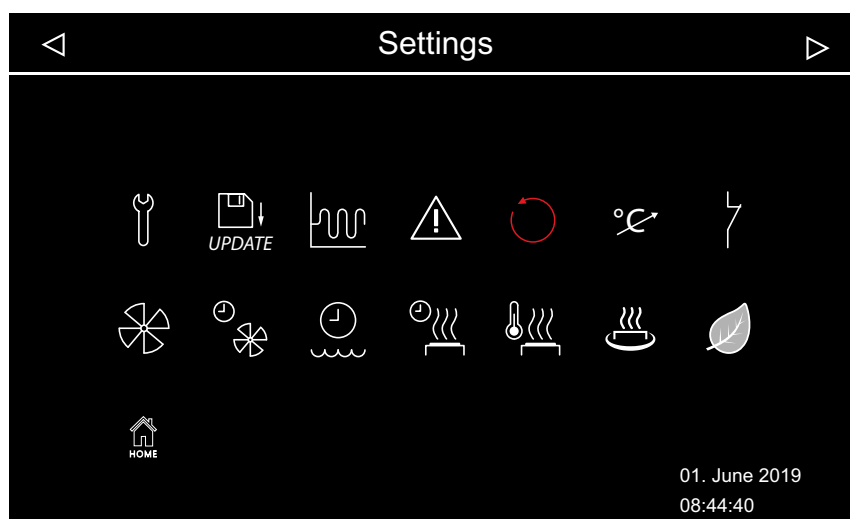

☒ Service settings – example: Installation with Bi-O heater



## Icons



Service/maintenance

- ▶ Defining the service interval, [EN-83](#)



Update,

- 6.2.2 Updating firmware, [EN-104](#)



Hysteresis

- ▶ Setting the switching hysteresis for the sauna heater, [EN-84](#)



Use

- ▶ Defining the type of use, [EN-19](#)



Reset function

- ▶ Resetting the settings, [EN-85](#)



Temperature control

- ▶ Setting the temperature control, [EN-86](#)



Potential-free contact

- ▶ Setting the potential-free contact, [EN-88](#)



Fan

- ▶ Activating or deactivating the fan, [EN-89](#)



Fan post-cycle period

- ▶ Setting the post-cycle period for drying the cabin, [EN-90](#)



Refill period

- ▶ Setting the post-cycle period for drying the cabin, [EN-90](#)



Post-heating time

- ▶ Setting the post-heating time, [EN-93](#)



Post-heating temperature

- ▶ Setting the post-heating temperature, [EN-94](#)



HOT function

- ▶ Configuring the HOT function, [EN-96](#)



ECO

- ▶ Setting the ECO mode runtime, [EN-98](#)



Home

- ▶ Making communication settings for the building management system, [EN-99](#)

## Service settings

### 6.1.1 Opening service settings

Settings at the service level must be made only by qualified personnel. Incorrect settings can lead to malfunctions or damage to the unit or the entire cabin.

In multi-cabin installations, service settings are set for each of the individual cabins.

#### ► Opening the service settings menu

- 1 Press and hold  for 3 seconds.
- 2 Enter code **5349** and confirm.

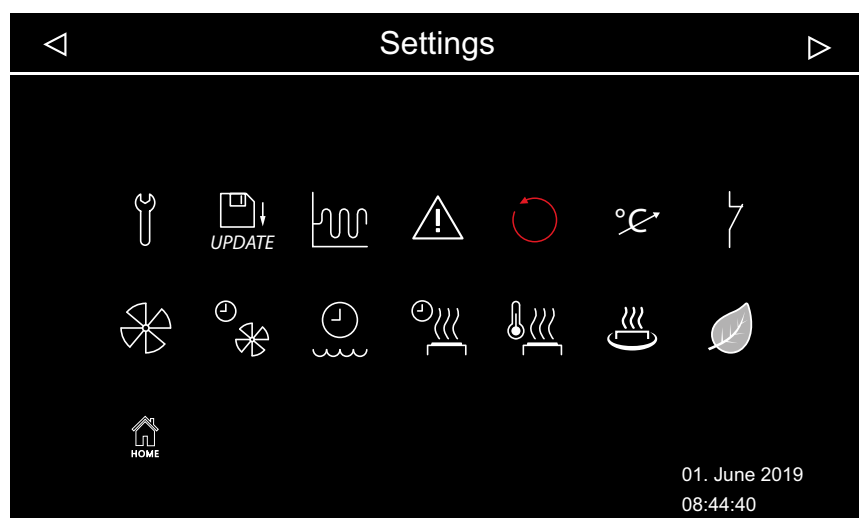
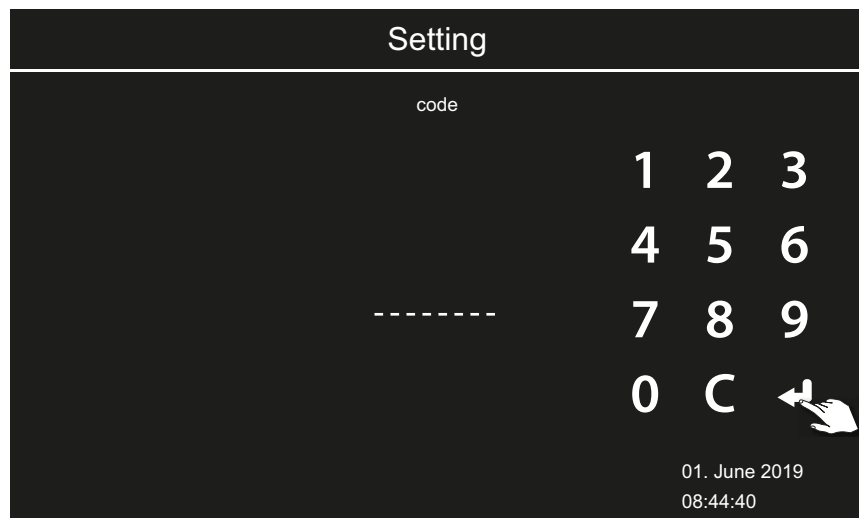

 Advanced settings (example with Bi-O sauna heater)



- 3 Tap the desired icon.

## 6.1.2 Service/maintenance

You can define the intervals for service/maintenance so that they are in line with operating conditions. The following values are set by the factory:

- Private use: 500 hours
- Commercial use: 2500 hours

### ► Defining the service interval

- 1 Open the service settings.  
① See 6.1.1 Opening service settings, [EN-82](#)
- 2 Tap  and confirm the selection.
- 3 Increase or decrease the displayed setting with  and .

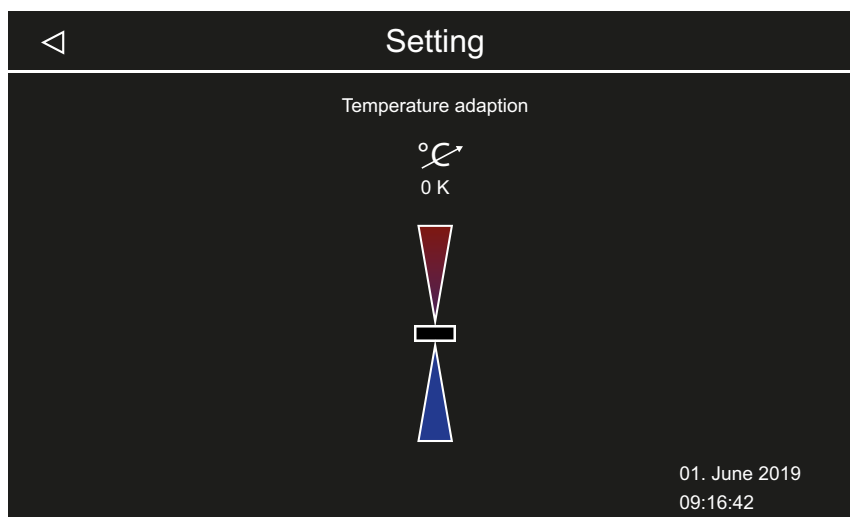

① The value can be increased or decreased by increments of 250.

- 4 Confirm the set value.  
① To check the amount of time remaining before service is required again, see ► Retrieving the next service date, [EN-60](#).

### 6.1.3 Switching hysteresis





You can set the switching hysteresis for a range of 1K to 10K. This allows you to change the upper and lower temperature limit, which determines when the control unit switches the sauna heater on and off. It allows you to adjust the temperature control to accommodate the size of the cabin with greater accuracy and optimize heat production.

Example — 90°C target temperature and hysteresis 5K: The sauna heater is switched on at 85°C and switched off at 95°C.

The interval is set to 5K by the factory.

Note that decreasing the value results in much more relay switching and therefore shortens the service life of the control unit.

#### ► Setting the switching hysteresis for the sauna heater

- 1 Open the service settings.  
 ⓘ See 6.1.1 Opening service settings, EN-82
- 2 Tap  and confirm the selection.
- 3 Set the value with  and , and then confirm by pressing .

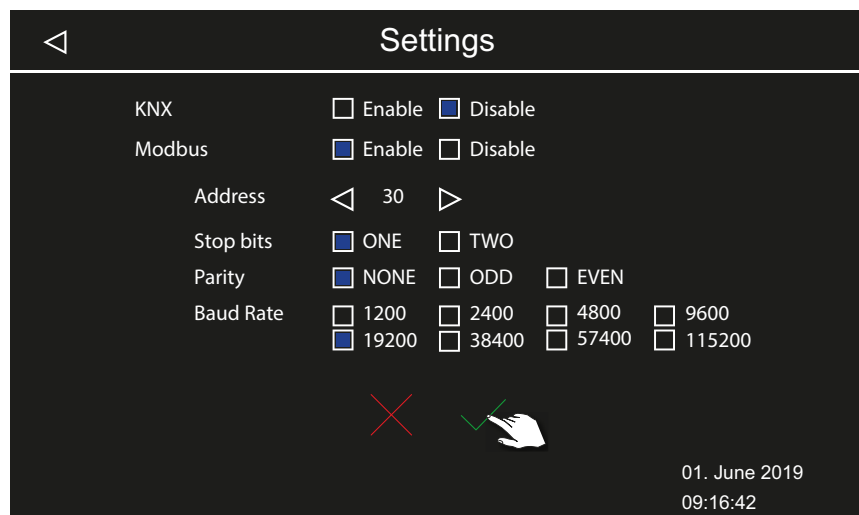

ⓘ The value can be set to any number between 1 and 10.

## 6.1.4 Reset function

You can perform a factory reset to restore the operating data or all of the settings.

### NOTICE

#### Resetting not possible

If a memory card has been connected prior to the reset, the saved settings are automatically read into the system again. This means the reset has no effect.

- ▶ Remove the memory card before resetting the system.

See 6.2 Data transfer and updates, [EN-100](#)

#### ▶ Resetting the settings

- 1 Open the service settings.
  - ① See 6.1.1 Opening service settings, [EN-82](#)
- 2 Tap  and confirm the selection.
- 3 Select the setting and confirm.
  - ① Any customised settings that have been set will be lost.

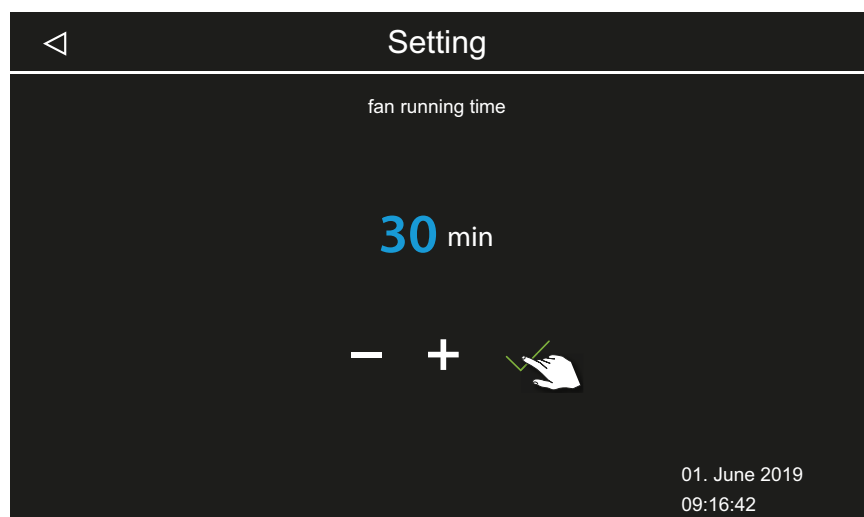

- a) Cabin: Reset only the settings for the current cabin.
  - b) All settings: All settings for all cabins are reset.
- If you reset the settings, the control unit restarts and the cabin settings must be reset. You can read in the old configuration again if you have made a backup. See 6.2.1 Configuration backup, [EN-101](#).

### 6.1.5 Temperature control

This function allows you to adjust the displayed actual temperature in relation to the actual ambient temperature. In the sauna, this offset can be increased or decreased by up to 10K; in the steam room, it can be regulated by up to 2K.

Example — 2K: The temperature is displayed approx. 2 K lower than it would be if a different measuring device were used.

This function should be set by experienced personnel only and must be sufficiently tested, as cabin temperatures may to become too high.

#### ► Setting the temperature control

- 1 Open the service settings.  
① See 6.1.1 Opening service settings, EN-82
- 2 Tap  and confirm the selection.
- 3 Set the slider to the desired off-set.

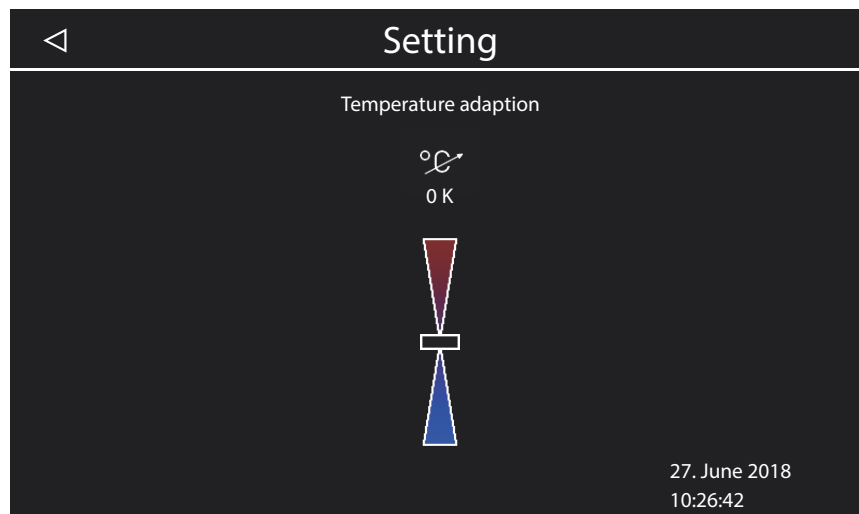

## 6.1.6 Setting the potential-free contact

You can connect any external device to terminals 3 and 4 on the circuit board of the relay box via the potential-free NC contact and couple this device's switching with various sauna heater functions.

For example, you can have additional cabin lighting switch on once the set cabin temperature (target) has been reached.

Observe the installation instructions and documentation for the device when retrofitting an additional device.

### NOTICE

#### Property damage due to short circuiting

The supply line can short circuit if you use the mains connections L1, L2 or L3 to supply the electric circuit connected to the potential-free contact.

- ▶ Use the EmoTouch 3 mains connections only for the sauna heater.
- ▶ Do not connect additional devices to the mains connections of the relay box.
- ▶ Connect the device connected to the potential-free contact and ensure that it is protected from short circuiting.
- ▶ Observe the maximum load of the potential-free contact: 10 A/ 2400 W.

Make settings for the potential-free contact to stipulate when the connected device should be switched on.

The following icons are used to make settings:



Manual switching on the display or via remote control



Deactivating the potential-free contact. The switch on the cabin image is not shown, the output becomes inactive.



Switch ON if light is currently on.



Switch ON if light is off.



Switch ON, once target temperature has been reached.



Switch ON until target temperature has been reached.



Switch ON if there is no water shortage. For Bi-O sauna only; not assigned for Finnish sauna.



Switch ON if there is a shortage of water in the vaporiser. For Bi-O sauna only; not assigned for Finnish sauna.



Switch for an additional vaporiser. Switch coupling to WB vaporiser outlet. For Bi-O sauna only; not assigned for Finnish sauna.



Switch ON, once actual temperature rises above 50°C (122°F).



Switch ON, once actual temperature drops below 50°C (122°F).

## Service settings



Switch ON if cabin is on.



Switch ON if cabin is off.



Automatic water splash after HOT function. For Finnish sauna only; not assigned for Bi-O sauna.

### ► Setting the potential-free contact

- 1 Open the service settings.  
 ⓘ See 6.1.1 Opening service settings, EN-82
- 2 Tap  and confirm the selection.
- 3 Tap the icon for the desired switching of the potential-free contact.

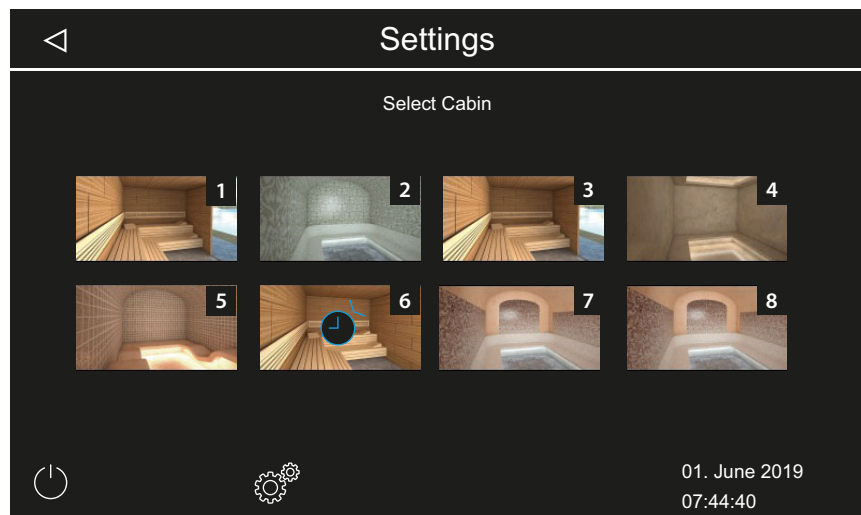

ⓘ The icons for the BiO sauna and for the sauna with humidity mode do not work for cabins with Finnish mode.

- 4 Choose the icon that should be assigned to the potential-free contact.  
 ⓘ The icon on the cabin image is displayed only with manual switching.



## 6.1.7 Fan levels

You can set the fan progressively from 0–100%, e.g. an exhaust fan.

- The fan is off if the setting is 0%.
- If the fan is set between 1% and 100%, the fan automatically switches on with the heating.

In the fan post-cycle period, the fan always runs at maximum power.

### ► Activating or deactivating the fan

- 1 Open the service settings.  
① See 6.1.1 Opening service settings, [EN-82](#)
- 2 Tap  and confirm the selection.
- 3 Move the slider to the desired level.

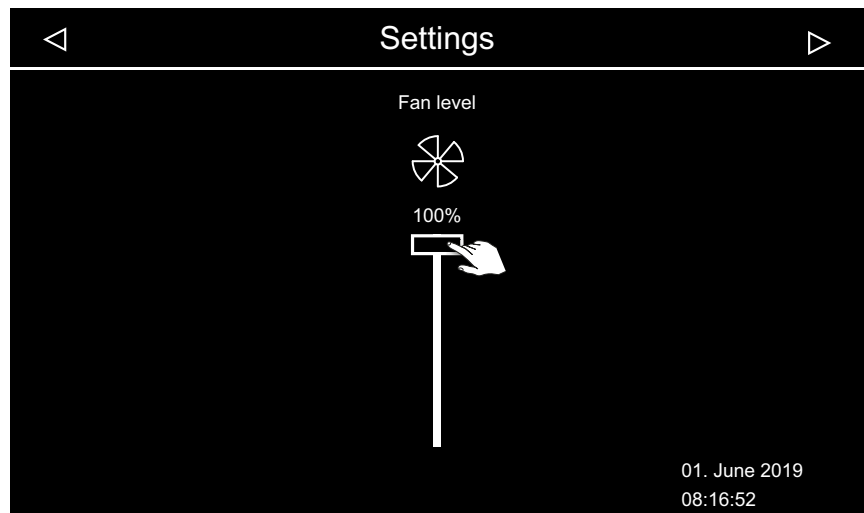



## Service settings

### 6.1.8 Fan post-cycle period

You can define the time in minutes for the fan post-cycle period after humidity mode. This function should be used together with the post-heating time to dry the sauna faster.

#### ► Setting the post-cycle period for drying the cabin

- 1 Open the service settings.  
 ⓘ See 6.1.1 Opening service settings, [EN-82](#)
- 2 Tap  and confirm the selection.  
 ⓘ The post-cycle period is coupled with the post-heating time. The runtime therefore appears in grey and cannot be changed. We recommend that you retain this coupling and change the setting for the post-heating time as needed.  
 ► Setting the post-heating time, [EN-93](#)
- 3 Tap  to remove the coupling.

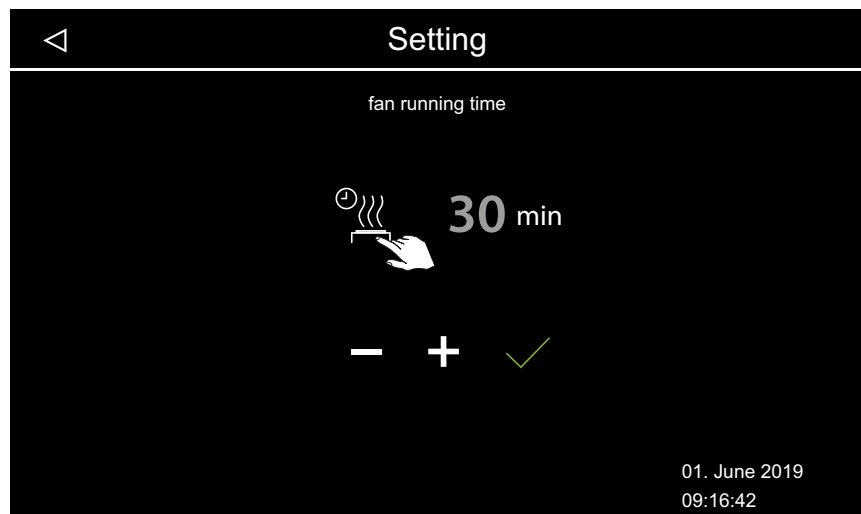

- ⓘ The minutes value can be changed.
- ⓘ It appears in white if the post-heating time is coupled. It appears in blue if the post-heating time is not coupled.

- 4 Set the value with **+** and **-**, and then confirm by pressing **✓**.

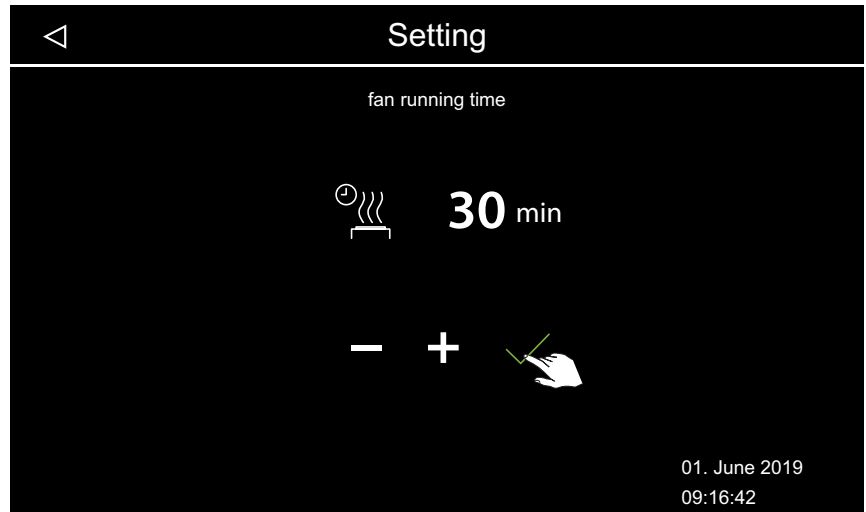

- ① The value can be set to any number between 0 and 60 minutes. The interval is set to 30 minutes by the factory.
- ① Verify that post-cycle has been assigned to a fan; see 6.1.7 Fan levels, [EN-89](#).

## Service settings





### 6.1.9 Refill period

This setting is available only in humidity mode.

You must set the time during which water must be added to the vaporiser if the display indicates a water shortage. If water is not added during the set time, the vaporiser is switched off (overheat protection).

This function is important for Bi-O heaters with manual water filling, in particular.

#### ► Refill period for humidity mode

- 1 Open the service settings.  
 ⓘ See 6.1.1 Opening service settings, □ EN-82
- 2 Tap  and confirm the selection.
- 3 Set the value with  and , and then confirm by pressing .

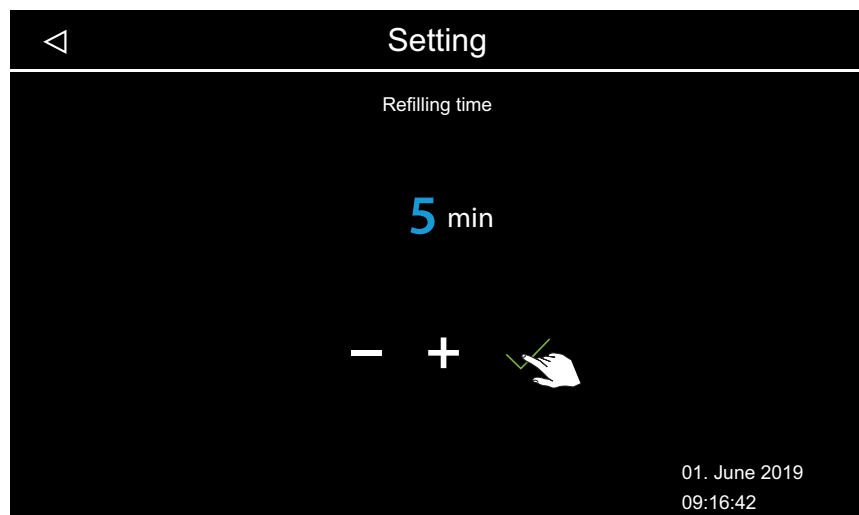

- ⓘ The value can be set to any number between 0 and 5 minutes. The interval is set to 0 minutes by the factory.





### 6.1.10 Post-heating time

This setting is available only in humidity mode. It is used to define how long the heater operates after humidity mode.

According to this setting, the sauna heater is switched on in Finnish mode after humidity mode to dry the sauna.

This function should be used together with the fan to remove any remaining humidity from the sauna more quickly. See also 6.1.8 Fan post-cycle period, [EN-90](#) and 6.1.11 Post-heating temperature, [EN-94](#)

#### ► Setting the post-heating time

- 1 Open the service settings.  
① See 6.1.1 Opening service settings, [EN-82](#)
- 2 Tap  and confirm the selection.
- 3 Set the value with  and , and then confirm by pressing .

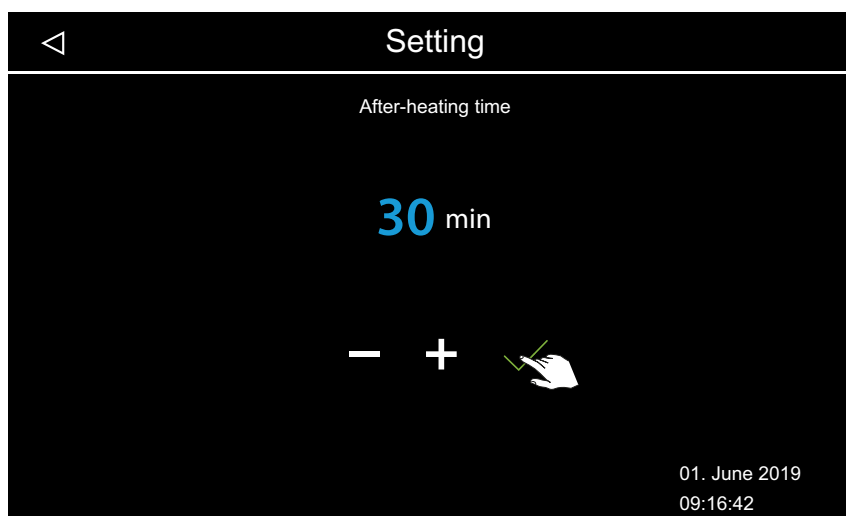

- ① The value can be set to any number between 0 and 30 minutes. The interval is set to 30 minutes by the factory.

## Service settings





### 6.1.11 Post-heating temperature

This setting is available only in humidity mode. It is used to set the temperature for the post-heating time.

See also

6.1.8 Fan post-cycle period, [EN-90](#) and 6.1.10 Post-heating time, [EN-93](#)

#### ► Setting the post-heating temperature

- 1 Open the service settings.  
[i](#) See 6.1.1 Opening service settings, [EN-82](#)
- 2 Tap  and confirm the selection.
- 3 Set the value with  and , and then confirm by pressing .

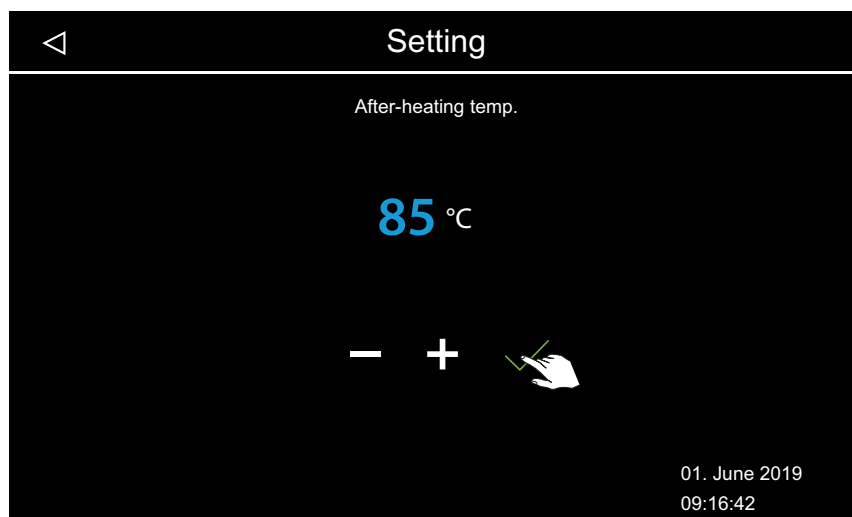

[i](#) The value can be set to any number between 30°C and 115°C.

### 6.1.12 HOT function

This setting is available only in Finnish mode. It allows you to define the time and temperature for operation at high temperatures in order to heat up the sauna stones to a maximum temperature before and/or during a water splash phase and keep them hot.

You can define a time period for the HOT function. During this period, the sauna heater heats at full power without interruption and independent of the control hysteresis and the actual air temperature. The heating process is interrupted for safety reasons once the air temperature reaches 115°C.

**Example:** HOT time period

Start time = 10:00

End time = 21:00

Interval = 60 minutes

Runtime = 15 minutes

With this setting, the HOT function starts 15 minutes (runtime) prior to each full hour between 10 am and 9 pm and ends on each full hour. The water splash can therefore take place on each full hour (interval).



HOT runtime  
Setting the HOT function runtime



HOT automatic interval time



HOT automatic start time



HOT automatic end time

The HOT function can be used to configure an automatic water splash, which can be started by a potential-free contact (PFC). This requires connection of a suitable device, such as the water splash assistant, EOS AquaDisp.

See 6.1.6 Setting the potential-free contact, [EN-87](#).

# Service settings

## ► Configuring the HOT function

1 Open the service settings.

ⓘ See 6.1.1 Opening service settings, EN-82

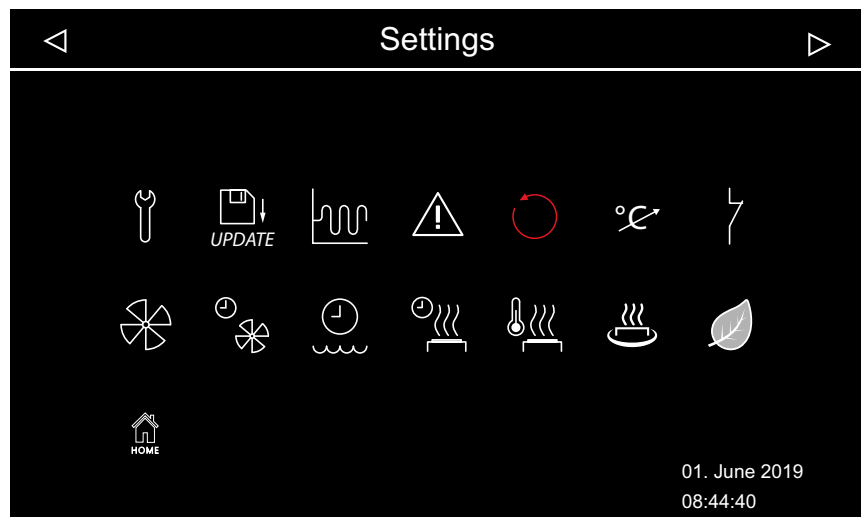

⊞ Advanced settings (humidity mode example)

2 Tap  and confirm the selection.

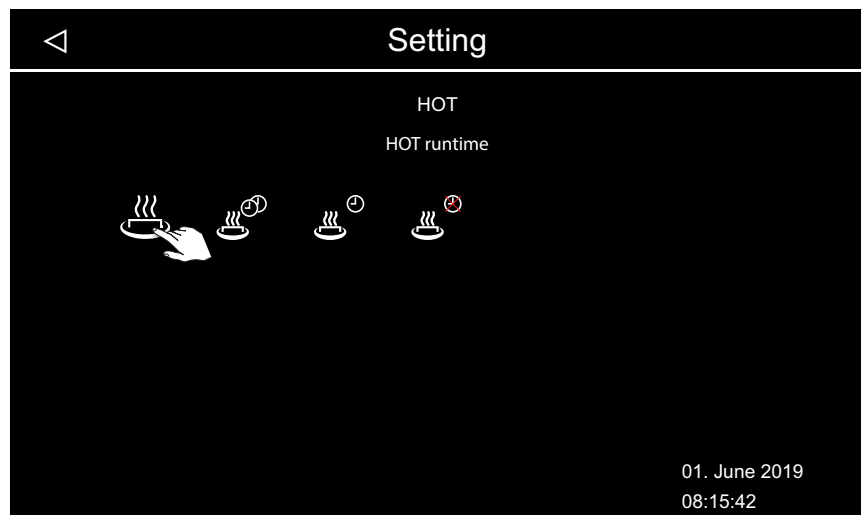

3 Set the runtime: tap  and confirm the selection.



- 4 Set the value by pressing  and .

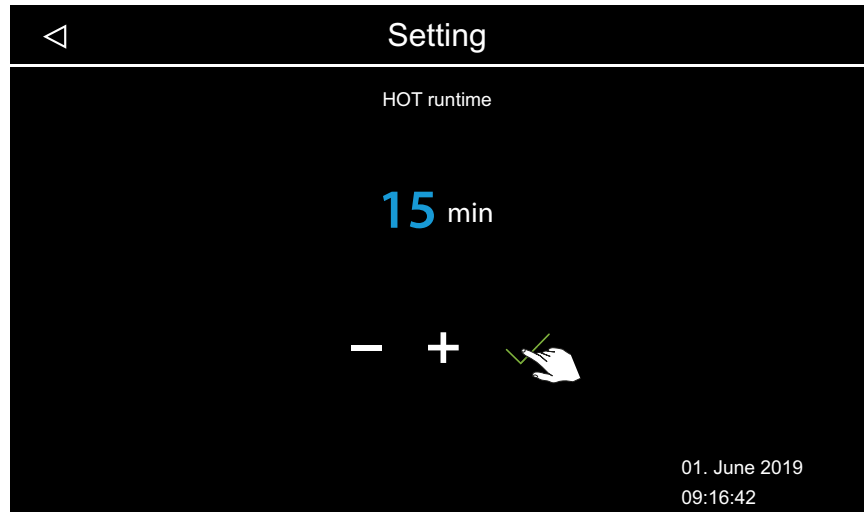



- ① The value can be set to any number between 5 and 20 minutes. The interval is set to 10 minutes by the factory.

- 5 Confirm the value by pressing .

- ① The screen for selecting the HOT functions is displayed again.

- 6 Set the following values in the same way:

- Set the interval: tap . Value range: 30–480 min., increment: 30 min., factory setting: 60 min.
- Set the start time: tap . Value range: 0:00–23:59, factory setting: 0:00. This setting deactivates the HOT automatic.
- Set the end time: tap . Value range: 0:00–23:59, factory setting: 0:00. This setting deactivates the HOT automatic.

## 6.1.13 Setting the ECO runtime

This function allows you to define a window of time during which the cabin temperature is lowered.

In the cabin, the ambient temperature is lowered as follows:

**Calculation:**  $T_{ECO} = T_{target} - ((T_{target} - 30)/2)$

$$T_{ECO} = (65 - (65 - 30)/2)$$

$$T_{ECO} = 65 - 17.5$$

$$T_{ECO} = 47.5^{\circ}\text{C}.$$





The window of time can be set to a value between 0 and 240 minutes in 30-minute increments.

The setting is useful if there are intermissions in operation to prevent the cabin from cooling down completely.

## Service settings

The ECO function is switched on via the control panel or via a push button that is available as an option. It is automatically switched off after the defined duration or ended by pressing the push button.

### ► Setting the ECO mode runtime

- 1 Open the service settings.  
 ⓘ See 6.1.1 Opening service settings, [EN-82](#)
- 2 Tap  and confirm the selection.
- 3 Set the value with  and , and then confirm by pressing .

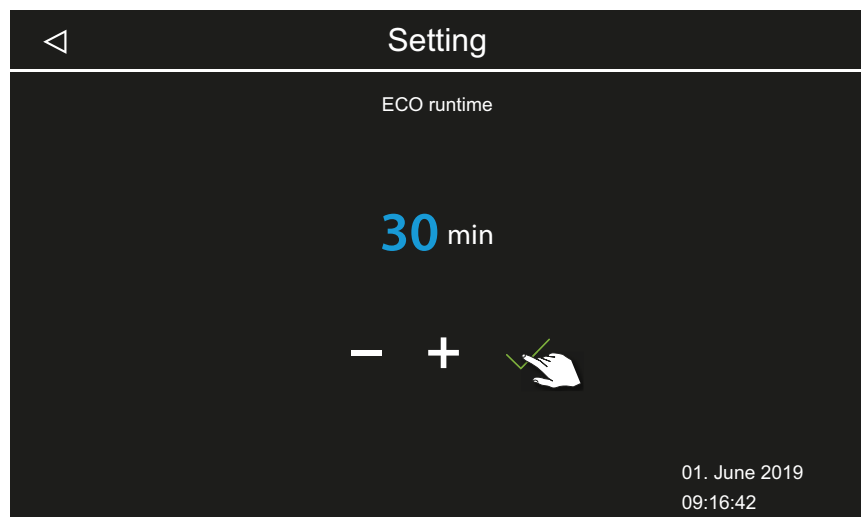

- ⓘ A value between 0 and 240 minutes can be selected in 30-minute increments. The ECO function starts if ECO mode is activated in the main menu or by pressing the push button that is available as an option.  
 See 5.4.7 Switching on HOT mode, [EN-41](#)
- ⓘ If the setting is 0 minutes, you must manually switch the ECO runtime on or off in the main menu or by pressing a button.



### 6.1.14 HOME function

You can control some functions for the sauna cabin with an external building management system. To do this, you must connect module SBM GLT KNX or SBM GLT MOD. The module must be configured to the type of building management system in use.

The following functions are supported:



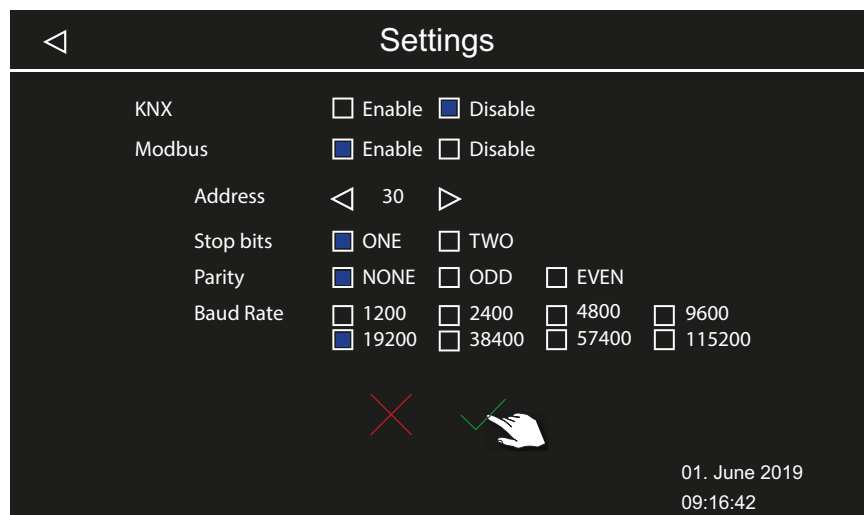

- Switch cabin on/off
- Switch light on/off or dim
- Set target temperature
- Switch potential-free contact on/off
- Display the actual temperature
- Switch between Bio and Finnish mode (Bi-O sauna only)
- Display actual humidity (Bi-O sauna only)
- Set target humidity (Bi-O sauna only)

### ► Making communication settings for the building management system

- 1 Open the service settings.  
① See 6.1.1 Opening service settings, EN-82
- 2 Tap  and confirm the selection.
- 3 Select KNX or Modbus as the transfer type by pressing .



- ① You are not required to set any additional values if you select KNX as the transfer protocol. Follow the steps below for the Modbus protocol.
- ① Applicable settings for the Modbus protocol can be found in the documentation for the application in use.

- 4 Set the address by pressing  and .
- 5 Set the values by choosing .
- 6 Confirm the set values by choosing .

## 6.2 Data transfer and updates

It is possible to connect a memory card (max. 32 GB) to the circuit board of the control panel. It can remain permanently connected. The memory card must be formatted with the FAT32 file system.

The memory card can be used to create backups and to transfer configuration data and updates.

If the memory card is connected permanently, changes to the configuration are written to the memory card as soon as the display switches to cabin view or multi-cabin view.

- The configuration data is written to the *CFG* folder.
- Backups are saved daily in the *BUP* subfolder.

The files are encrypted:

- *T3\_cfg.dat* includes the general EmoTouch 3 settings, e.g. language, standby time and usage settings.
- *T3\_CabinX\_cfg.dat* includes cabin-specific settings, e.g. cabin type, target temperature and fan settings.

### Restoring the configuration

If the factory settings have been reset on the control panel and it is started with a memory card that contains the saved configuration data, this data is automatically read.

Therefore, the reset function is ineffective if a memory card has been inserted because the configuration data on the memory card is automatically read upon restart.

Importing a configuration is possible for version R2.10 or higher. If there are different versions, settings that are not available are managed as follows:

- From a newer version to an older version:  
Settings that were not available in the older version are ignored.
- From an older version to a newer version:  
Settings that have been included in the newer version are assigned default values.

### Connecting the memory card

The front panel must be removed to insert the memory card. Use a removal tool or a flathead screwdriver to remove the front panel.

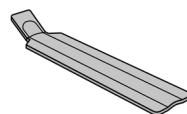

- ▶ Dismantling the front panel, [EN-101](#)

## NOTICE

### Damage to the unit due to improper dismantling

The display can become scratched. The circuit board can break.

- ▶ Do not tilt the front panel when dismantling.
- ▶ Apply a consistent amount of pressure to the removal tool or screwdriver when using it.
- ▶ Do not scratch the front panel with the tools.

## 6.2.1 Configuration backup

Once a configuration has been fully set up, a backup should be created and saved on an external storage device, e.g. on a PC or hard drive. With this data, the configuration can be restored quickly after a reset or reboot.

If you want to restore a configuration with a backup, the backup files must be copied to the *CFG* folder on the memory card.

You must carry out the following steps to create and read a backup:

- ▶ Dismantling the front panel, [EN-101](#)
- ▶ Saving the backup, [EN-102](#)
- ▶ Installing the backup, [EN-103](#)

### ▶ Dismantling the front panel

- 1 Switch the off switch on the relay box to 0.
- 2 Insert the removal tool in the slot at the base of the control panel between the front panel and the housing.

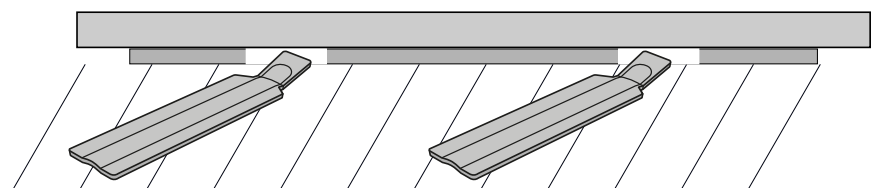

- |                        |                       |
|------------------------|-----------------------|
| <b>A</b> Front panel   | <b>C</b> Bottom piece |
| <b>B</b> Removal tools | <b>D</b> Wall         |

- 3 **NOTICE** Do not tilt the front panel to avoid damage to the display. Press the removal tool against the wall until the front panel comes loose from the bottom piece.
- 4 Remove the front panel with a consistent amount of force from the housing.
- 5 Rotate the front panel to the side until the circuit board is easy to access.

## Service settings

### ► Saving the backup

- 1 Insert the memory card into the circuit board of the control panel.

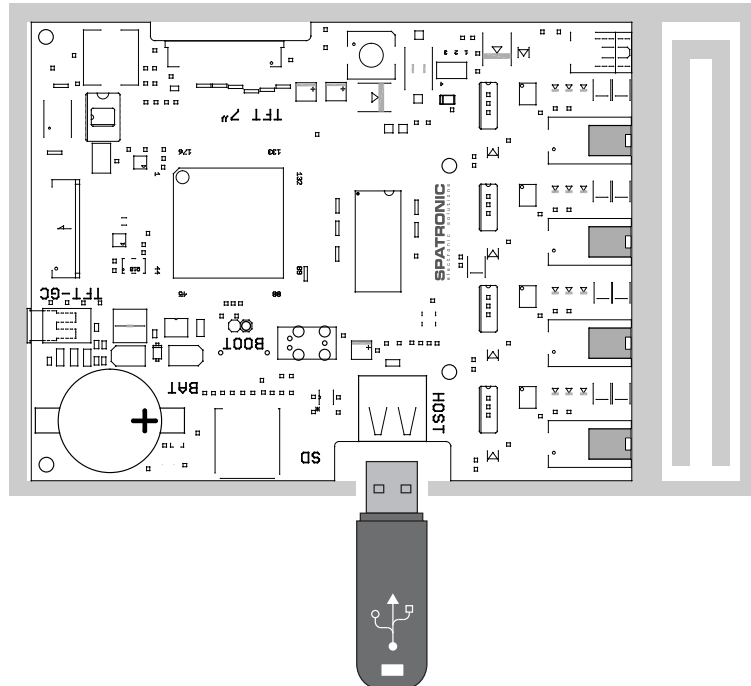

- 2 Switch the off switch on the relay box to I.
  - ⓘ The configuration data is automatically written to the memory card. It takes a few seconds for the system to detect the memory card and write the data to it. After inserting the memory card, wait at least 30 seconds before removing it.
- 3 Remove the memory card.
  - ⓘ Save the data from the memory card on a PC or hard drive.
- 4 Place the front panel directly in front of the housing.
  - ⓘ Ensure that it is aligned properly. The S-Bus connection must face downward.

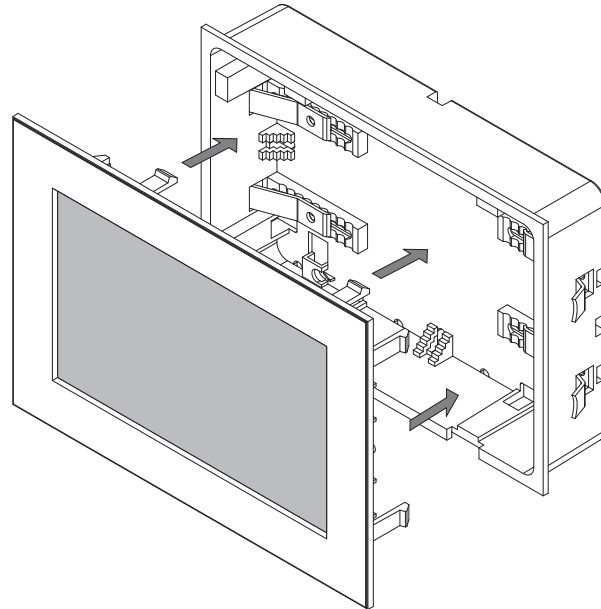

① Position the connecting cable in the bottom piece so that it is not pinched.

5 Press the front panel carefully with a consistent amount of pressure into the housing until it audibly snaps into place.

### ► Installing the backup

1 Transfer the backup saved to the memory card to the *CFG* folder.

2 Remove the front panel.

① ► Dismantling the front panel, [EN-101](#)

3 Plug in the memory card.

① The configuration in the *CFG* folder is automatically read after a full reset with an inserted memory card or if the initial setup is not yet complete.

## 6.2.2 Updating firmware

You need an empty memory card to update the software.

You can obtain the update from EOS as follows:

- Memory card with firmware.
- ZIP file with the zipped update files as a download from the EOS home page.

### NOTICE

#### Equipment damage due to a faulty update

The device can become unusable if the update is interrupted.

- ▶ Ensure that the power supply is not interrupted during the update process.
  - ▶ The update must be performed by trained personnel only.
- 

Ensure that you have a backup of the old software version on your PC or an external drive. You will need this old version in the event that the update is not successful. See 6.2.1 Configuration backup, [EN-101](#).

- ▶ Preparing the update, [EN-104](#)
- ▶ Installing the update, [EN-105](#)
- ▶ Rebooting after a malfunction when updating, [EN-107](#)

#### ▶ Preparing the update

- 1 Download the most recent firmware from the EOS website.  
[i eos-sauna.com/service-support/software](https://eos-sauna.com/service-support/software)
- 2 Extract the ZIP file on the memory card.



## ► Installing the update

- 1 **NOTICE** Ensure that the power supply is not interrupted during the update process.  
Insert the memory card into the circuit board of the control panel.

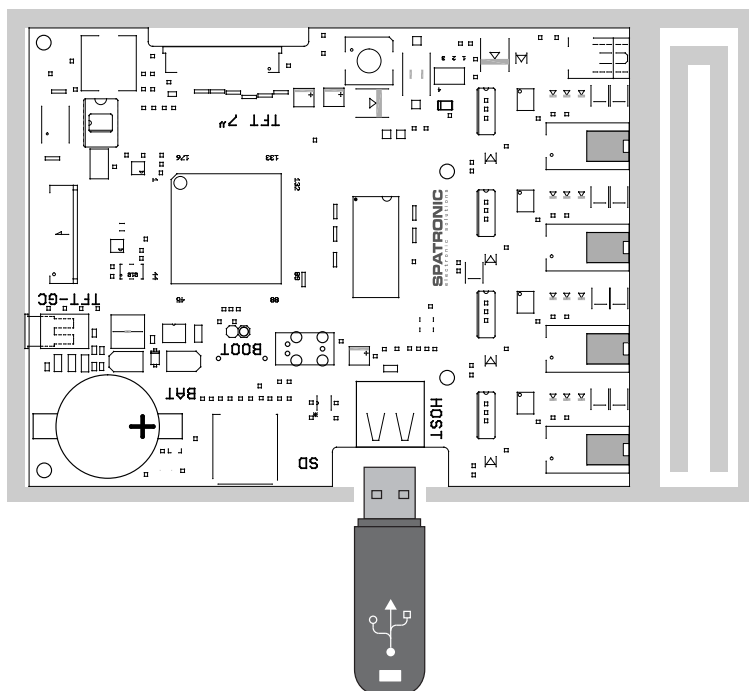

- 2 Switch the off switch on the relay box to I.
- 3 Open the service settings on the EmoTouch 3 control panel.  
① See 6.1.1 Opening service settings, EN-82

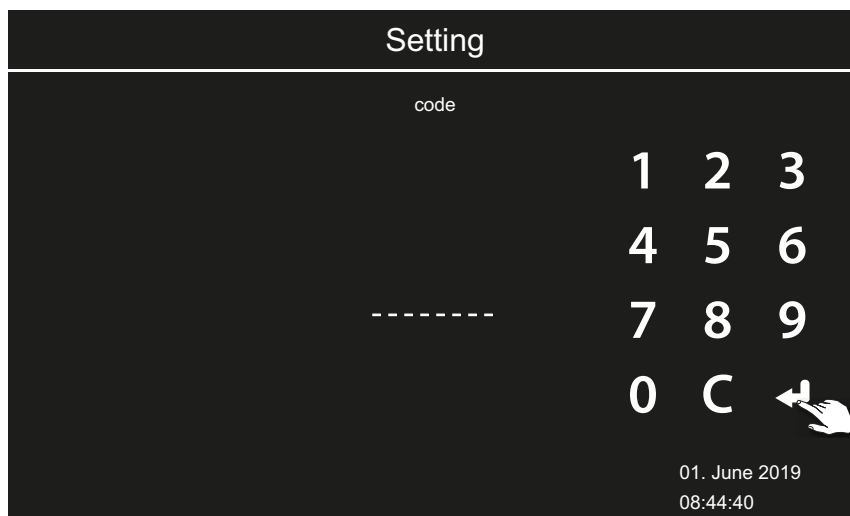

- 4 Enter code **543210**.

## Service settings

- 5 Select the component that requires updating.



The following options are available depending on the installation:

- a) Panel (control panel)
  - b) Relay box for the current cabin
  - c) Coloured light module for the current cabin
  - d) Sound module for the current cabin
- 6 Tap Select to start the sub-menu.
- The process is started and the progress of the update is shown on the display. The update can last a few minutes. The control unit restarts automatically once the update is complete.
  - ❗ The update was not successful if there is no icon after the relay box switches back on or if the software crashes during operation. You should then start a circuit board reboot and re-install the update.
  - ❗ **Error message:** The required data were not found. Check the data on the memory card and repeat the update. Download the data again as needed.
  - ❗ **Power interruption:** The update process resumes once the power supply is restored. If an error message is displayed, press the reset button on the circuit board. The control unit is reset and starts again. Repeat the update.
  - ❗ If the malfunction is not resolved, reset the settings completely by rebooting; see ► Rebooting after a malfunction when updating, EN-107.
- 7 Once the update has been successfully installed, remove the memory card and replace the front panel.
- ❗ The update was not successful if there is no icon after the relay box switches back on or if the software crashes during operation. You should then start a circuit board reboot and re-install the update.

## ► Rebooting after a malfunction when updating

- 1 Press the Reset button.

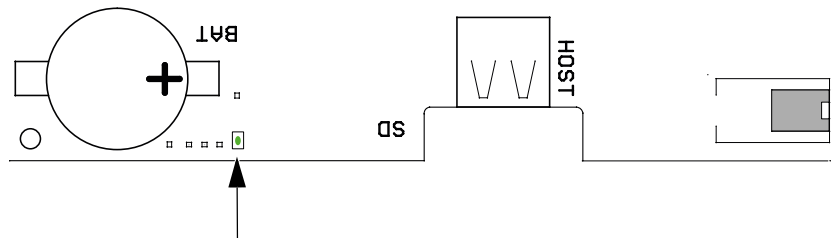

- ① The software is restarted. The software version and the configuration are not modified.

- 2 Repeat the update.

## 6.2.3 Exporting the operating data

You can have an EOS Saunatechnik GmbH technician check the error messages by loading the messages onto the memory card and sending the card to EOS.

### ► Exporting the operating data

- 1 Switch the off switch on the relay box to I.
- 2 Insert the memory card to export data.
  - ① See ► Installing the update, EN-105.
- 3 Switch on the relay box again and wait approx. 30 seconds.
  - ① The operating data is automatically written to the memory card.
  - ① The operating data is written to the LOG folder with the file name *T3\_[serial number]\_Dat.json*.
- 4 Switch off the relay box again.
- 5 Remove the memory card.
  - ① It takes a few seconds for the system to detect the memory card and write the data to it. Therefore, you should wait at least 30 seconds before removing it again.
- 6 Replace the front panel.
- 7 Send the operating data to the service address.

# 7

## General terms and conditions of service

(T&C, Dated 008-2018)

### I. Scope

Unless otherwise agreed in writing for specific instances, these terms and conditions of service shall apply to service operations, including reviewing and remedying complaints. All our existing or future legal relationships shall be governed solely by the following terms and conditions of service. We do not recognise any of the customer's conflicting terms and conditions unless we have given our express written consent to their applicability.

We hereby expressly object to any of the customer's terms and conditions included in the customer's General Terms and Conditions of Business or order confirmation. Unconditional acceptance of order acknowledgments or deliveries shall not be construed as any form of acknowledgment of such terms and conditions. Ancillary agreements or amendments must be confirmed in writing.

### II. Costs

The customer shall bear the following costs in connection with services rendered:

- Mounting/dismantling and electrical (de-)installation
- Transportation, postage and packaging
- Function testing and troubleshooting, including inspection and repair costs

There shall be no third-party billing.

### III. Performance and cooperation obligations

The customer shall provide assistance free of charge to the manufacturer in rendering services.

In the case of a warranty claim, the manufacturer shall provide spare parts necessary for servicing free of charge.

### IV. Service visit by the manufacturer

Services rendered on site by an employee of the manufacturer must be agreed in advance.

If the main reason for the service visit is not the fault of the manufacturer, any costs incurred shall be charged to the customer after the service visit and must be paid by the customer in full within the agreed payment term.

## **V. Liability**

The manufacturer shall assume liability in accordance with the currently applicable statutory regulations. All our products are packaged in such a way that the individually packed goods (pallets) can be shipped. We wish to point out that our packaging is not suitable for individual shipments via parcel post. The manufacturer shall accept no liability for damages incurred as a result of improper packaging in an individual shipment.

## **VI. Manufacturer's warranty**

The manufacturer's warranty shall apply only if installation, operation and maintenance have been carried out in full accordance with the manufacturer's specifications in the installation and operating instructions.

- The warranty period shall commence from the date on which proof of purchase is provided and shall be limited, in all cases, to 24 months.
- Warranty services shall be performed only if proof of purchase of the equipment can be presented.
- Any and all warranty claims shall become void if modifications are made to the equipment without the manufacturer's express consent.
- Any warranty claim shall likewise become void in the case of defects that arise due to repairs or interventions made by unauthorised persons or due to improper use.
- In the case of warranty claims, the serial and article numbers must be provided, together with the unit designation and a meaningful description of the error.
- This warranty shall cover defective equipment parts, with the exception of normal wear parts. Wear parts shall include, for example, light sources, glass elements, tubular heating elements and sauna heater stones.
- Only original spare parts may be used within the warranty period.
- Service visits made by third parties shall require a written order issued by our service department.
- The equipment in question shall be sent to our service department by the customer at the customer's own expense.
- Electrical assembly and installation work, including service visits and parts replacements, shall be carried out at the customer's expense; costs shall not be borne by the manufacturer.

Complaints in respect of our products shall be reported to the responsible distributor and shall be handled exclusively by said distributor.

## General terms and conditions of service

The manufacturer's General Terms and Conditions of Business, in the version available at [www.eos-sauna.com/agb](http://www.eos-sauna.com/agb), shall apply in addition to the foregoing terms and conditions of service.

# 8

## Disposal

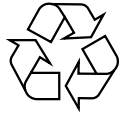

Electrical devices that are no longer needed must be recycled at a recycling station as per EU guideline 2012/19/EU or as per the Electrical and Electronic Equipment Act (ElektroG). Observe local provisions, laws, regulations, standards and directives when disposing of the unit.



Do not dispose of the unit with household waste.

### Packaging

The packaging of the EmoTouch 3 can be completely separated for disposal and recycled. The following materials are used in the packaging:

- Used paper, cardboard
- Plastic
- Foam material

### Electronic waste

Electronic waste must be disposed of at the designated local collection point for electronic waste.

**Service address**

EOS Saunatechnik GmbH

Schneiderstriesch 1

35759 Driedorf, Germany

Tel. +49 2775 82-514

Fax +49 2775 82-431

Email [servicecenter@eos-sauna.com](mailto:servicecenter@eos-sauna.com)

Web [www.eos-sauna.com](http://www.eos-sauna.com)

Store this address with the operating instructions in a safe place.  
Please always provide us with nameplate data, such as model, item number and serial number so we can provide fast and efficient support.

**Date of sale**

**Stamp/retailer signature:**